

GCS11-953/1353 SERIES UNITS

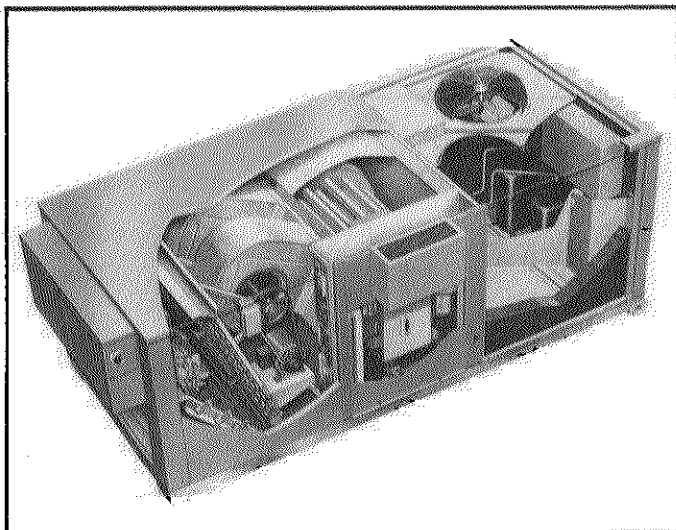

TABLE 1

Option	Model No.		Availability
	GCS11-953	GCS11-1353	
Power Saver	PSD11-95	PSD11-135	Factory or Field Installed
Gravity Exhaust Dampers	GED11-95	GED11-135	Field Installed Only
Minimum Fresh Air Dampers (Manual)	OAD11-95	OAD11-135	Field Installed Only

Option	Model No.		Availability
	GCS11-953	GCS11-1353	
Automatic Fresh Air Damper Kit For OAD11	34C23	34C23	Field Installed Only
Night Setback Kit	LB-38134CB	LB-38134CB	Field Installed Only
Roof Mounting Frame	RMFG11-95	RMFG11-135	Field Installed Only
Horizontal Frame Adaptor	RMFGH11-95	RMFGH11-135	Field Installed Only
Ceiling Supply And Return Step-Down Diffuser	RTD11-95	RTD11-135	Field Installed Only
Ceiling Supply And Return Flush Diffuser	FD11-95	FD11-135	Field Installed Only
Ceiling Supply And Return Transitions	SRTG11-95	SRTG11-135	Field Installed Only
Remote Status Panel	SP11	SP11	Field Installed Only
Remote Switching Status Panel	SSP11	SSP11	Field Installed Only
Low Ambient Kit	LB-37124B	LB-37124B	Field Installed Only
Disconnect Mounting Kit	LB-38208BA	LB-38208BA	Field Installed Only

TABLE OF CONTENTS

I - INTRODUCTION.....Page 2	IV - REFRIGERANT SYSTEMPage 19
GCS11 Control Option ChartPage 2	V - GCS11 HEATING SYSTEM.....Page 19
II - UNIT INFORMATION	VI - BLOWER OPERATION AND ADJUSTMENTSPage 23
Specifications — Electrical Data.....Page 3	VII - THERMOSTAT OR TRANSMITTER OPERATION.....Page 23
Dimensions — Installation ClearancesPage 4	VIII - GCS11 UNIT OPTIONS
Burner Ratings — Blower PerformancePage 5	Power Saver.....Page 23
Pressure Curves — RMFG11 Roof Mounting FramePage 6	Fresh Air Dampers — Low Ambient Kit — Night Setback.....Page 26
Combination Ceiling Supply & Return.....Page 7	Status Panel.....Page 29
RMFGH11 Horizontal Mounting Frame.....Page 8	IX - FIRESTATSPage 29
RMFGA11 Adaptor Mounting Frame — Field Wiring.....Page 9	X - MAINTENANCE.....Page 29
Low Voltage Field Wiring Diagrams...Pages 10 & 11	XI - GENERAL SCHEMATIC INFORMATION.....Page 30
III - GCS11 COMPONENTS	Unit DiagramsPage 32 - Page 35
Main Control Box — Make-up Box — Compressor CompartmentPage 13	XII - OPERATING SEQUENCE
Heating Compartment.....Page 14	Cooling Mode.....Page 36
Blower Compartment - Component Index.....Page 17	Heating Mode.....Page 38
	XIII - TROUBLESHOOTINGPage 41

I - INTRODUCTION

GCS11 production is scheduled in 1980 for the 7-1/2 and 10 ton models. Figure 1 shows a unit cutaway. GCS11 unit options are listed in Table 1.

Units are designed for rooftop installation with either bottom or horizontal discharge. The RMFG11 roof mounting frame mates to the bottom of unit. The added installation of a RMFGH11 mounting frame permits horizontal discharge. A

RMFGA11 mounting frame adaptor allows unit installation on an existing RMF3 roof mounting frame in retrofit applications.

The GCS11 incorporates the "Honeywell Single Zone Solid State Control System." Figure 2 illustrates the compatible control options and lists the corresponding ordering numbers.

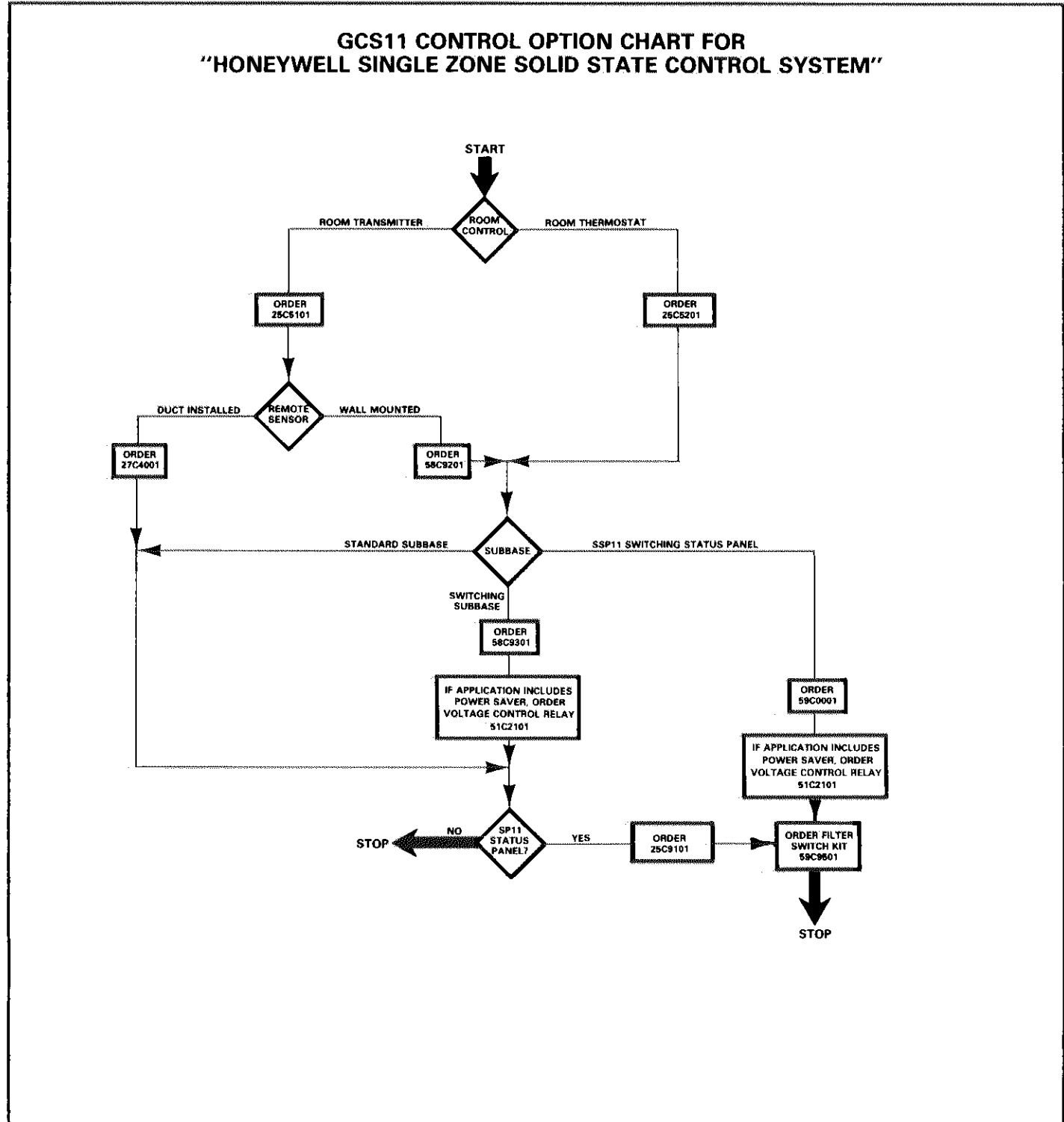

FIGURE 2

II - UNIT INFORMATION

A - Specifications

Model No.		GCS11-953	GCS11-1353
★ARI Standard 270 SRN		21	22
Single Stage Heating Capacity Natural	Btuh Input	175,000	230,000
	Btuh Output	131,000	172,500
Two Stage Heating Capacity Natural & **LPG	Btuh Input (Low)	145,000	195,000
	Btuh Output (low)	108,700	146,000
	Btuh Input (high)	250,000	330,000
	Btuh Output (high)	187,500	247,500
*ARI Standard 210 Ratings	Total cooling capacity (Btuh)	89,000	121,000
	Total unit watts	11,100	15,100
	†EER (Btuh/Watts)	8.0	8.0
	Dehumidifying capacity	29%	31%
Refrigerant (22) charge		15 lbs. 6 oz.	21 lbs. 6 oz.
Evaporator Blower	Blower wheel nominal diam. x width (in.)	(2) 12 — 6	(2) 12 — 12
	Motor horsepower (minimum-maximum)	1-1/2 — 3	2 — 3
Evaporator Coil	Net face area (sq. ft.)	8.3	12.0
	Tube diam. (in.) & No. of rows	1/2 — 3	1/2 — 3
	Fins per inch	15	15
Condenser Coil	Net face area (sq. ft.)	14.6	19.8
	Tube diam. (in.) & No. of rows	3/8 — 3	3/8 — 3
	Fins per inch	20	20
Condenser Fans	Diameter (in.) & No. of blades	(2) 20 — 4	(2) 24 — 4
	Air volume (cfm) (factory setting)	6000	8500
	Motor horsepower	(2) 1/3	(2) 1/2
	Motor watts (factory setting)	850	1150
Gas Supply Connection fpt (in.)	Natural	3/4	3/4
	**LPG	3/4	3/4
Recommended Gas Supply Pressure (wc. in.)	Natural	6	6
	**LPG	11	11
Condensate drain size mpt (in.)		(2) 3/4 - (2) 3/8	(2) 3/4 - (2) 3/8
No. & size of filters (in.)		(4) 16 x 20 x 1	(6) 16 x 20 x 1
Net weight of basic unit (lbs.) (1 Package)		1600 lbs.	2000 lbs.

B - Electrical Data

Model No.		GCS11-953								GCS11-1353							
Line voltage data -- 60 Hz -- 3 phase		200V		230V		460V		575V		200V		230V		460V		575V	
Compressors (2)	Rated load amps (total)	29.8	28.2	14.2	11.4	42.0	42.0	21.0	16.8	42.0	42.0	21.0	16.8	132.0	106.0		
	Locked rotor amps (total)	152.0	152.0	74.0	60.0	264.0	264.0	132.0	106.0	264.0	264.0	132.0	106.0	6.4	5.8		
Condenser Fan Motors (2)	Full load amps (total)	4.6	4.6	2.4	2.0	6.0	6.0	2.8	2.4	6.0	6.0	2.8	2.4	6.4	5.8		
	Locked rotor amps (total)	8.6	8.6	4.6	4.0	12.4	12.4	6.4	5.8	12.4	12.4	6.4	5.8	6.4	5.8		
Evaporator Blower Motor	Horsepower	1-1/2	3	1-1/2	3	1-1/2	3	1-1/2	3	2	3	2	3	2	3	2	3
	Full load amps (total)	6.3	11.4	5.6	10.0	2.8	5.0	2.2	4.0	7.5	11.4	6.0	10.0	3.0	5.0	2.4	4.0
	Locked rotor amps (total)	39.0	65.0	34.0	56.0	17.0	28.0	14.0	25.6	55.4	65.0	46.0	56.0	23.0	28.0	18.0	26.3
Recommended maximum fuse size (amps)		60	60	50	60	25	30	20.0	20.0	80	80	80	80	40	40.0	30.0	35.0
*Minimum Circuit Ampacity		45.4	49.5	42.9	46.3	22.2	23.3	18.0	19.8	61.8	65.5	60.3	64.3	30.4	32.4	24.7	26.8
Unit power factor		.90	.89	.90	.89	.90	.89	.90	.89	.85	.85	.85	.85	.85	.85	.85	.85

*Refer to National Electric Code manual to determine wire, fuse and disconnect size requirements.

NOTE - Extremes of operating range are plus and minus 10% of line voltage.

C - Dimensions

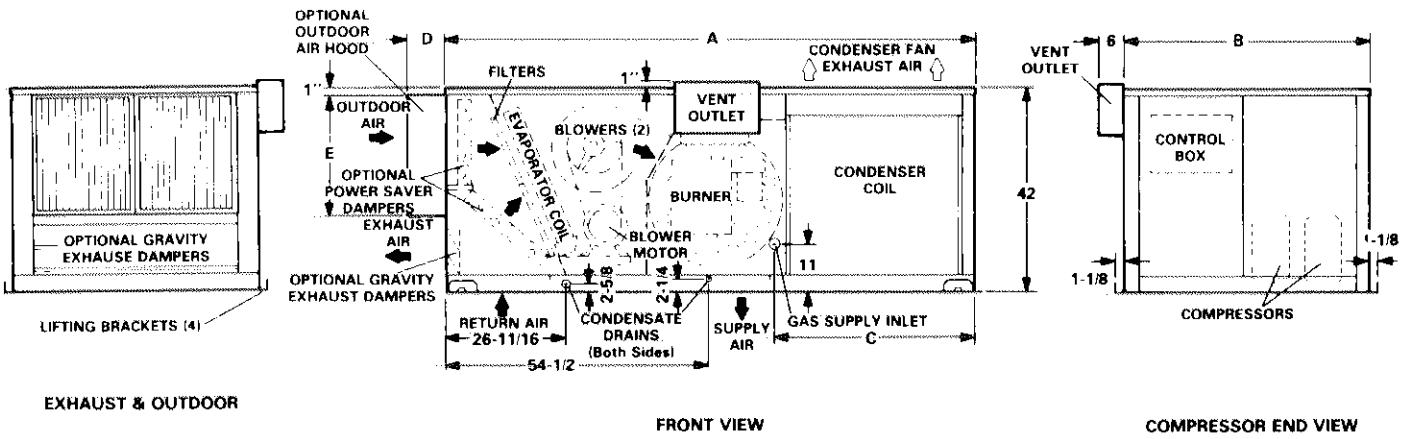
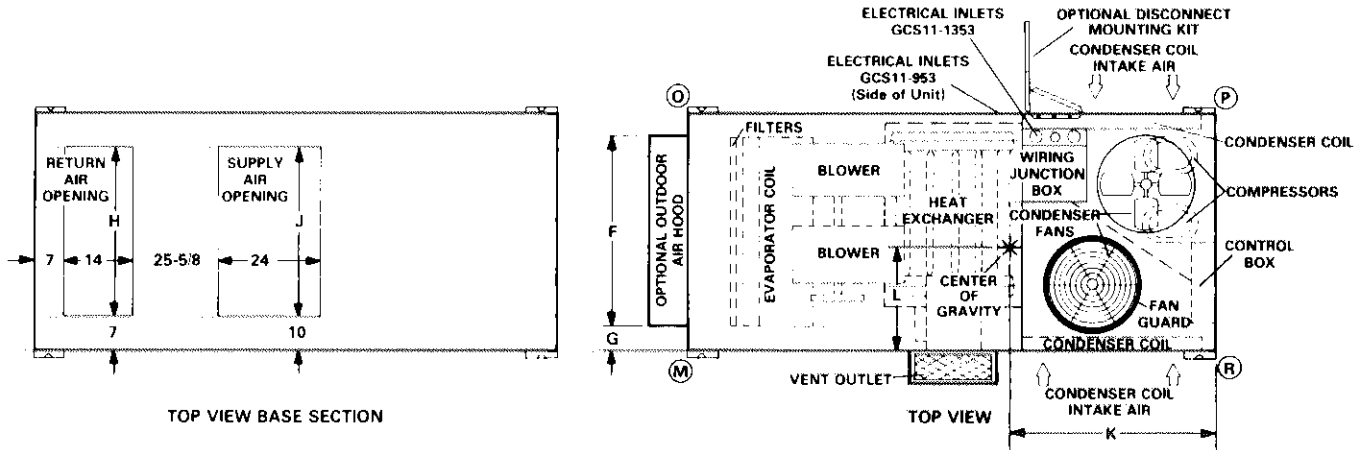

Model No.	A	B	C	D	E	F	G	H	J
GCS11-953	111	50	42	6-1/8	20-3/4	40-3/4	4-1/2	35-9/16	32-9/16
GCS11-1353	116-1/2	68	47-1/2	14-1/8	32	63	2-3/8	53-9/16	47-9/16

D - Installation Clearances

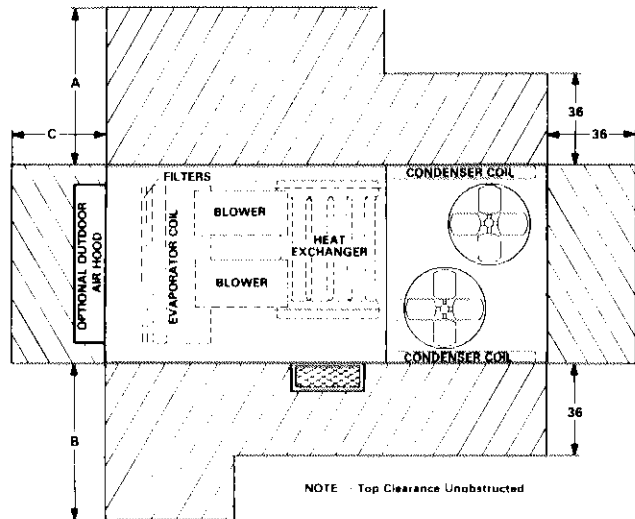

Model No.	A	B	C
GCS11-953	50	50	24
GCS11-1353	68	68	36

E - Burner Ratings

BURNER MODEL	GAS TYPE	ALTITUDE	INPUT (BTUH)		OUTPUT (BTUH)	
PG3-175 (A.G.A. ONLY)	Natural	----	175,000		131,000	
PG3-230 (A.G.A. ONLY)	Natural	----	230,000		172,000	
*PG3-250/145	Natural or L.P.	0 - 2000 ft.	MAX. 250,000	MIN. 145,000	MAX. 211,000	MIN. ----
	Natural or L.P.	2000 - 4500 ft.	225,000	145,000	189,900	----
*PG3-330/195	Natural or L.P.	0 - 2000 ft.	330,000	195,000	274,890	---
	Natural or L.P.	2000 - 4500 ft.	297,000	195,000	247,400	----

*2 stage burner

F - Blower Performance

GCS11-953 BLOWER PERFORMANCE

Air Volume (Cfm)	STATIC PRESSURE EXTERNAL TO UNIT — (Inches Water Gauge)										
	0	.10	.20	.30	.40	.50	.60	.70	.80	.90	1.00
	RPM BHP	RPM BHP	RPM BHP	RPM BHP	RPM BHP	RPM BHP	RPM BHP	RPM BHP	RPM BHP	RPM BHP	RPM BHP
2600	630 0.60	690 0.75	745 0.80	795 0.95	840 1.10	880 1.20	920 1.30	955 1.45	990 1.55	1025 1.65	1060 1.75
2800	680 0.75	735 0.85	785 1.00	835 1.15	875 1.28	915 1.40	955 1.55	990 1.65	1025 1.80	1055 1.90	1080 2.00
3000	725 0.85	780 1.05	830 1.20	875 1.35	910 1.45	955 1.65	990 1.80	1030 1.90	1055 2.00	1085 2.10	1105 2.25
3200	770 0.95	825 1.25	870 1.40	915 1.55	955 1.70	990 1.85	1035 2.05	1060 2.15	1085 2.25	1110 2.40	1140 2.55
3400	820 1.50	870 1.45	910 1.60	955 1.80	995 2.00	1030 2.15	1065 2.25	1090 2.45	1115 2.55	1145 2.70	1175 2.85
3600	870 1.55	910 1.70	960 1.90	995 2.10	1035 2.20	1070 2.40	1095 2.60	1125 2.75	1155 2.95	1180 3.05	1190 3.10
3800	915 1.75	960 1.95	1000 2.20	1040 2.35	1075 2.60	1100 2.75	1130 2.90	1165 3.10	1190 3.25	1270 3.45	----

NOTE — All Cfm data is measured external to the unit with the air filters in place.

GCS11-1353 BLOWER PERFORMANCE

Air Volume (Cfm)	STATIC PRESSURE EXTERNAL TO UNIT — (Inches Water Gauge)										
	0	.10	.20	.30	.40	.50	.60	.70	.80	.90	1.00
	RPM BHP	RPM BHP	RPM BHP	RPM BHP	RPM BHP	RPM BHP	RPM BHP	RPM BHP	RPM BHP	RPM BHP	RPM BHP
3800	610 0.80	670 0.95	720 1.12	765 1.25	815 1.45	850 1.61	880 1.70	915 1.80	950 1.90	985 2.05	1020 2.17
4000	645 0.92	695 1.10	745 1.25	795 1.45	835 1.60	870 1.75	900 1.82	935 1.92	970 2.05	1000 2.15	1040 2.35
4200	675 1.12	725 1.30	775 1.45	820 1.65	855 1.85	890 1.90	925 1.95	960 2.10	990 2.20	1025 2.35	1060 2.55
4400	705 1.35	755 1.50	805 1.65	840 1.80	880 1.95	910 2.05	945 2.10	980 2.25	1010 2.40	1045 2.55	1080 2.80
4600	735 1.55	785 1.70	830 1.85	865 2.00	895 2.05	940 2.20	970 2.30	1000 2.42	1035 2.60	1070 2.80	1100 3.00
4800	770 1.80	815 1.90	855 2.05	885 2.15	925 2.30	960 2.40	990 2.50	1020 2.65	1055 2.85	1090 3.05	1120 3.20
5000	805 2.00	840 2.15	880 2.30	910 2.40	950 2.50	980 2.60	1010 2.85	1045 2.95	1080 3.00	1110 3.30	1140 3.45
5200	830 2.30	865 2.45	900 2.55	940 2.70	975 2.80	1005 2.90	1035 3.05	1070 3.25	1100 3.45	----	----
5400	860 2.65	890 2.75	930 2.90	970 3.05	995 3.15	1030 3.30	1060 3.45	----	----	----	----
5600	885 3.05	920 3.20	960 3.35	990 3.45	----	----	----	----	----	----	----

NOTE — All Cfm data is measured external to the unit with the air filters in place.

G - Pressure Curves

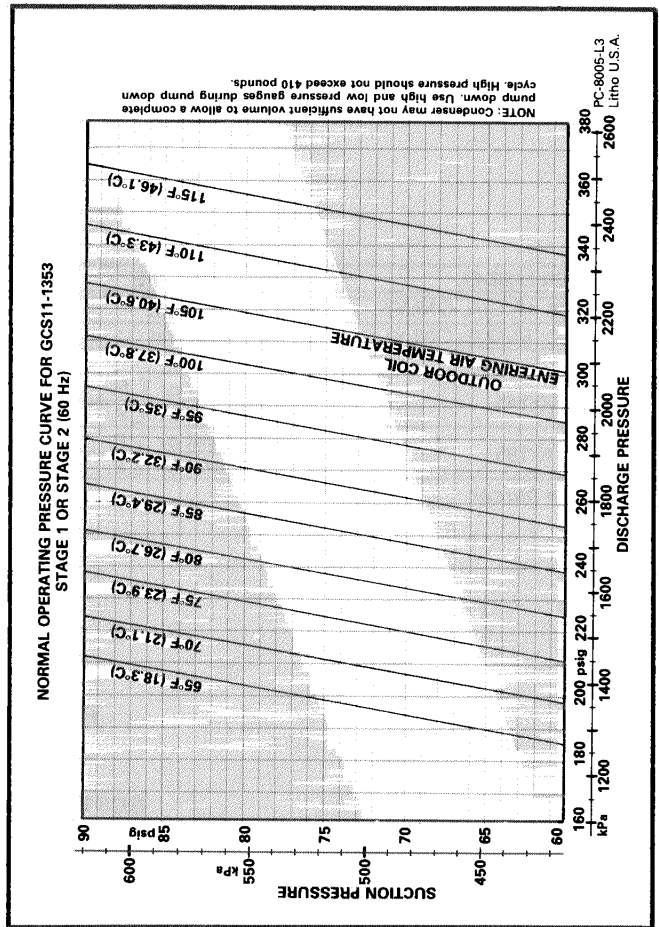
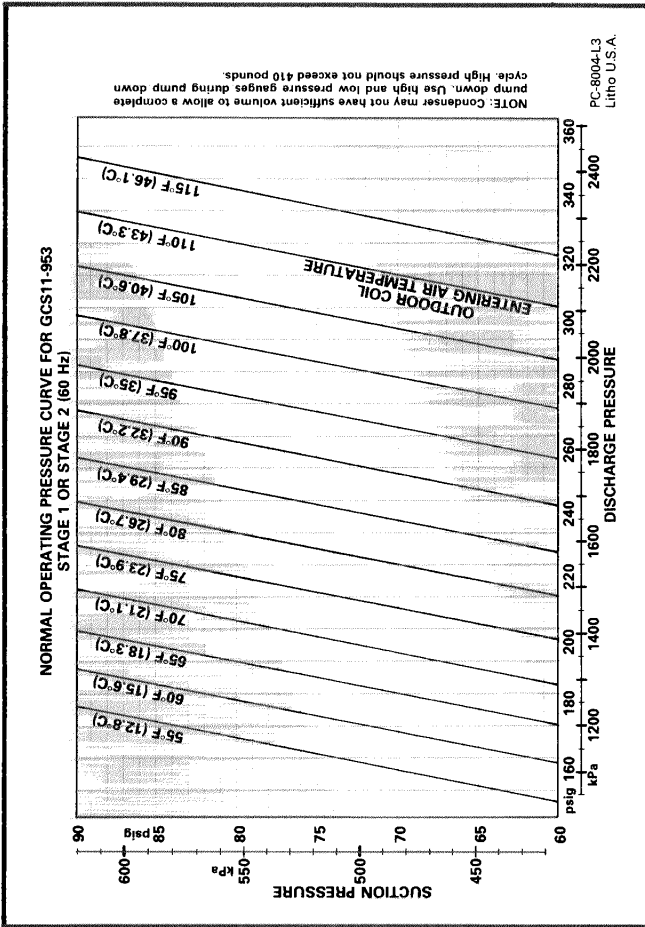

H - RMFG11 Roof Mounting Frame

DOUBLE DUCT APPLICATION

RECOMMENDED FLASHING FOR RMFG11 ROOF MOUNTING FRAME

RMFG11 ROOF MOUNTING FRAME WITH DOUBLE DUCT OPENING

CORNER ANGLE
(4 furnished for frame assembly)

NOTE — Roof deck may be omitted within the confines of frame

Model No.	A	B	C	D	E	F	G
RMFG11-95	102-5/8	98-5/8	41-5/8	37-5/8	37-5/8	----	34-5/8
RMFG11-135	108-1/8	104-1/8	59-5/8	55-5/8	55-5/8	49-5/8	----

I - RMFG11 Roof With Combination Ceiling Supply And Return

GCS11-953 WITH FD11-95 FLUSH DIFFUSER

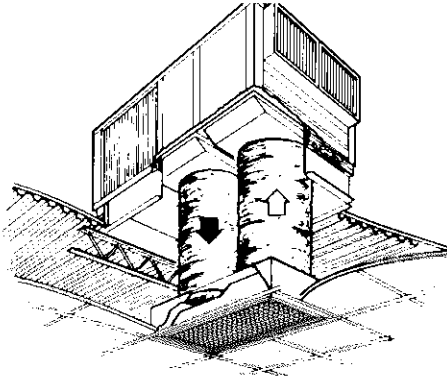

RMFG11 ROOF MOUNTING FRAME WITH FD11-95 & RTD11-95 CEILING SUPPLY AND RETURN

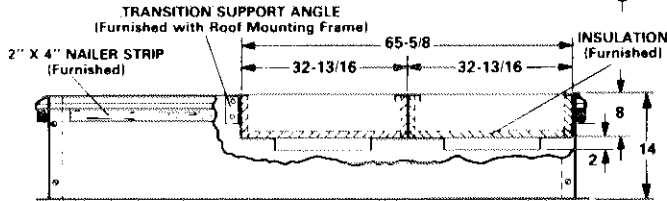
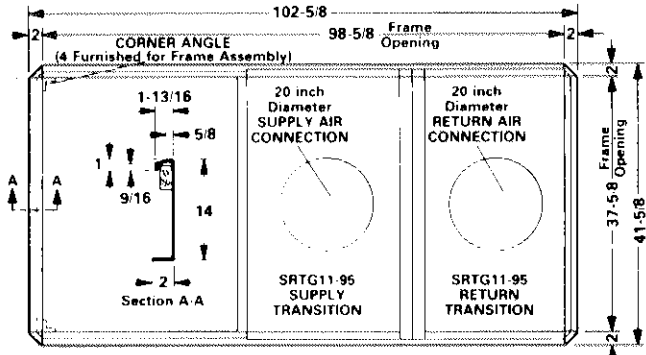

RTD11-95 STEP-DOWN CEILING DIFFUSER

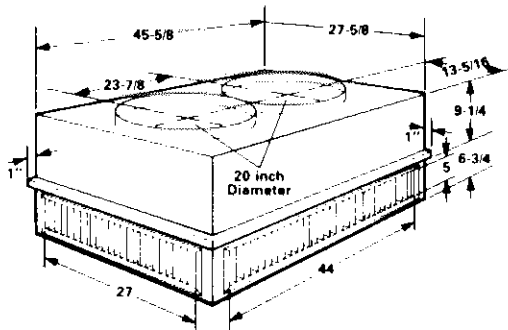

FD11-95 FLUSH CEILING DIFFUSER

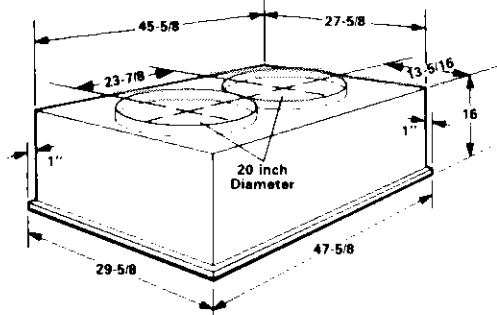

GCS11-1353 WITH FD11-135 FLUSH DIFFUSER

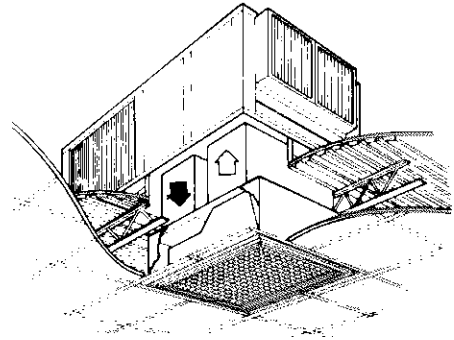

RMFG11 ROOF MOUNTING FRAME WITH FD11-135 & RTD11-135 CEILING SUPPLY AND RETURN

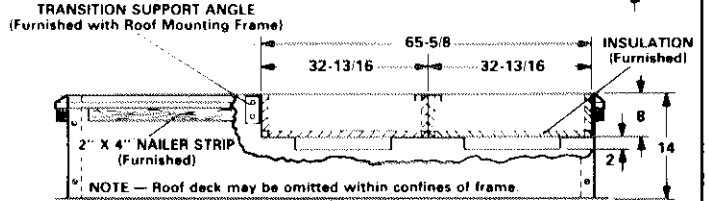
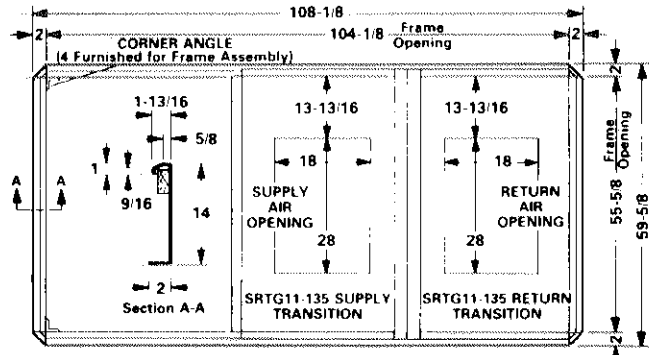

NOTE — Roof deck may be omitted within confines of frame.

RTD11-135 STEP-DOWN CEILING DIFFUSER

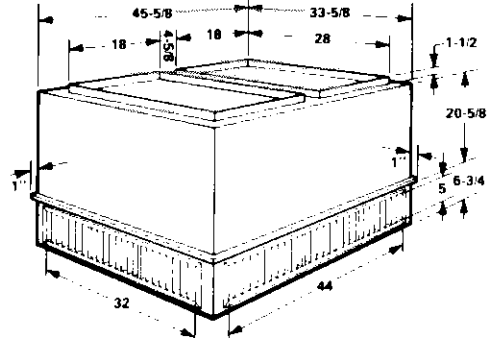

FD11-135 FLUSH CEILING DIFFUSER

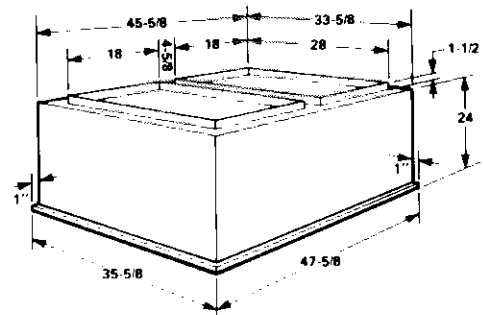

K - RMFGA11 Adaptor Mounting Frame

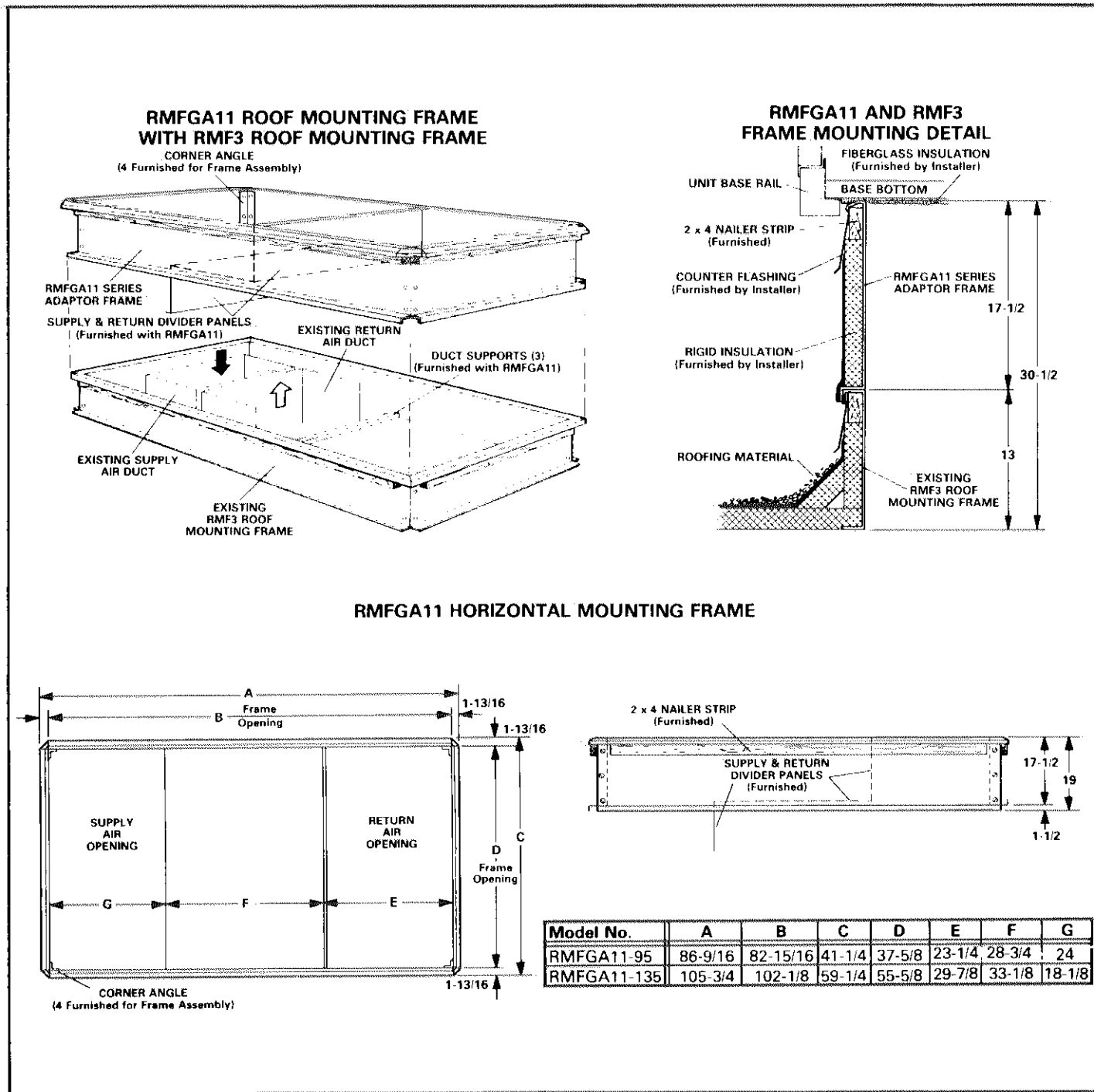

L - Power Supply Wiring

The power supply junction box is located at the top of unit. Power supply wiring enters through the large conduit fitting. Refer to GCS11 dimension drawing on page 4. The unit rating plate lists minimum circuit ampacity and maximum fuse size. Use copper conductors only. Connect power supply to high voltage leads in make-up box.

M - Low Voltage Field Wiring

- 1 - Low voltage connections are made at the terminal block located in the low voltage junction box.
- 2 - If switching subbase or switching status panel is used, remove jumper between TBC-9 and TBC-10.
- 3 - Figure 3 illustrates field wiring for room thermostat or transmitter, switching subbase and status panel. Figure 4 illustrates field wiring for room thermostat or transmitter and switching status panel. Do not route DC wires in same conduit or raceway as AC current. AC will interfere with the DC ramp signals.

GCS11 LOW VOLTAGE FIELD WIRING
(With Switching Subbase And SP11 Status Panel)

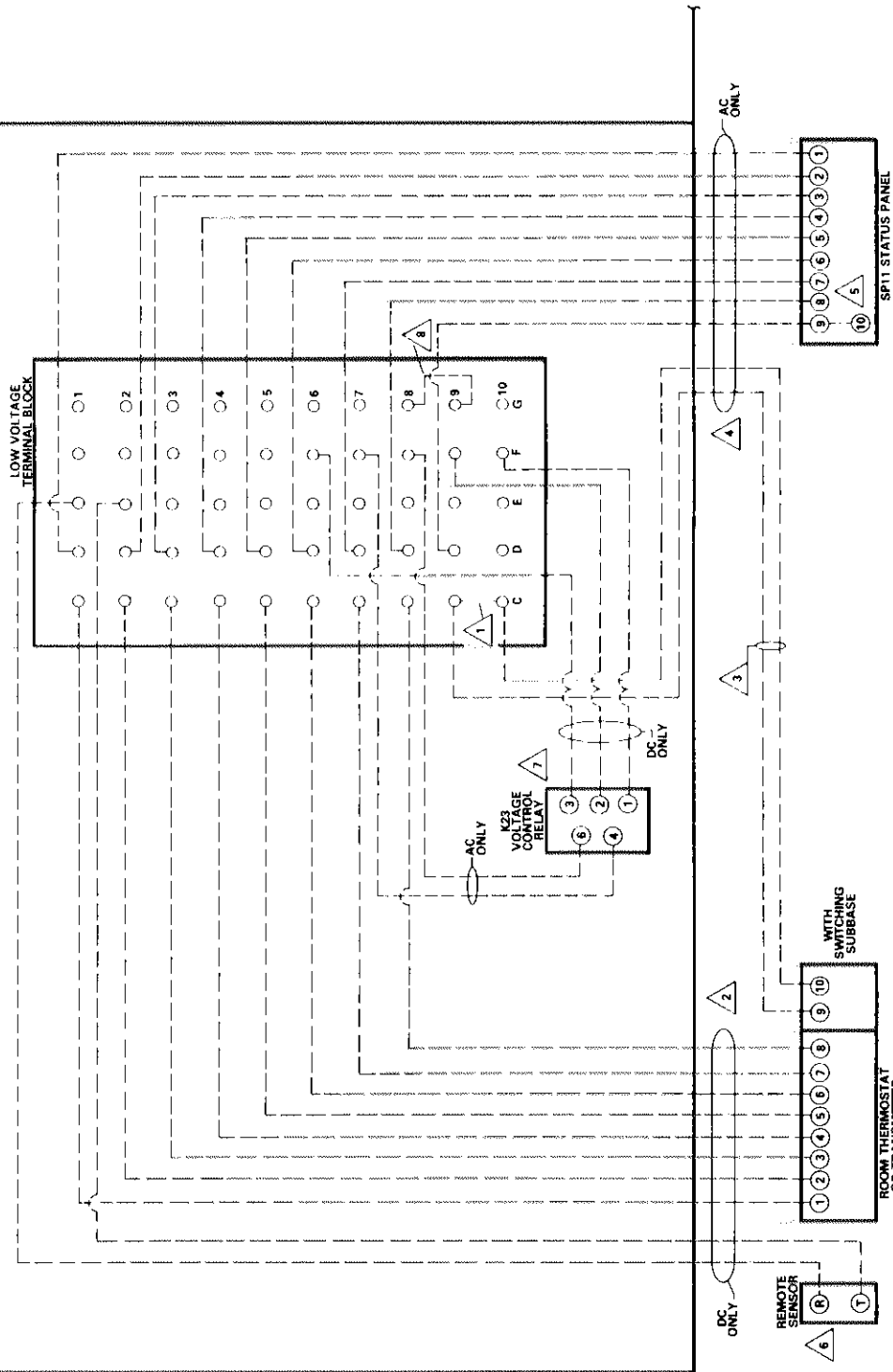

- 5 - IF SP11 IS USED, JUMPER TERMINALS 9 AND 10.
- 6 - IF ROOM TRANSMITTER IS USED, RUN 2 D.C. WIRES FROM ROOM SENSOR TO LOW VOLTAGE TERMINAL BLOCK.
- 7 - IF APPLICATION INCLUDES POWER SAVER, WIRE K23 VOLTAGE CONTROL RELAY AS SHOWN.
- 8 - FACTORY INSTALLED JUMPER, MUST REMAIN IN PLACE.

- 1 - IF SWITCHING SUBBASE IS USED, REMOVE JUMPERS BETWEEN TB-C 9 AND TB-C 10.
- 2 - RUN 8 D.C. WIRES FROM LOW VOLTAGE TERMINAL BLOCK TO ROOM CONTROL AND WIRE AS SHOWN.
- 3 - IF SWITCHING SUBBASE IS USED, RUN 2 A.C. WIRES FROM ROOM CONTROL TO TERMINAL BLOCK.
- 4 - IF SP11 STATUS PANEL IS USED, ROUTE 9 ADDITIONAL A.C. WIRES FROM STATUS PANEL TO TERMINAL BLOCK.

FIGURE 3

GCS11 LOW VOLTAGE FIELD WIRING
(With SSP11 Switching Status Panel)

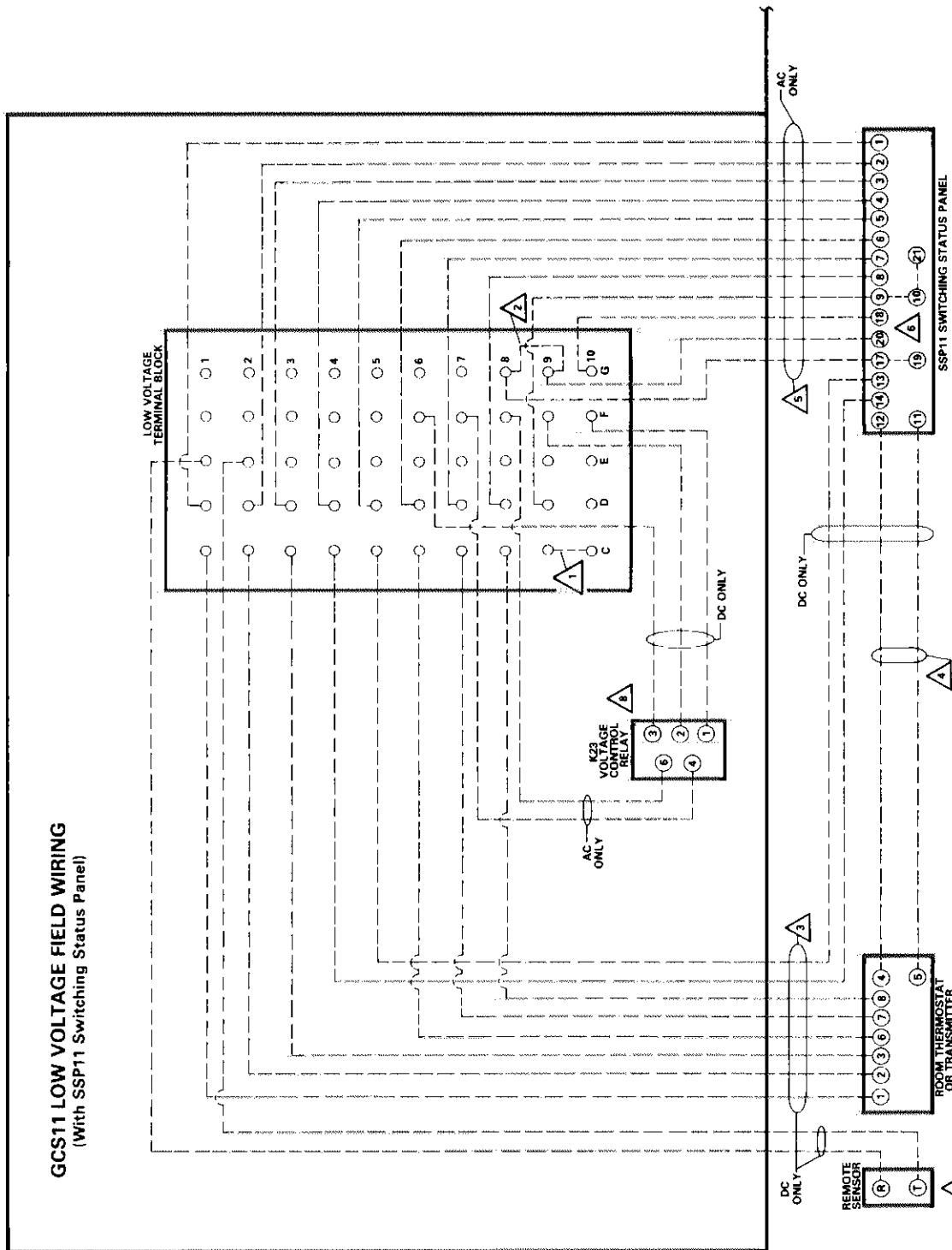

- 5 - RUN 12 A.C. WIRES FROM SSP11 TO TERMINAL BLOCK.
- 6 - JUMPER TERMINALS AT SSP11, AS SHOWN
- 7 - IF ROOM TRANSMITTER IS USED, RUN 2 D.C. WIRES FROM REMOTE SENSOR TO LOW VOLTAGE TERMINAL BLOCK.
- 8 - IF APPLICATION INCLUDES POWER SAVER, WIRE K23 VOLTAGE CONTROL RELAY AS SHOWN

- 1 - REMOVE JUMPER BETWEEN TB-C9 AND TB-C10.
- 2 - REMOVE JUMPER BETWEEN TB-G 8 AND TB-G9.
- 3 - RUN 8 D.C. WIRES FROM LOW VOLTAGE TERMINAL BLOCK TO ROOM CONTROL. CONNECT 5 WIRES TO ROOM CONTROL AND ROUTE 2 WIRES TO SSP11 SWITCHING STATUS PANEL.
- 4 - RUN 2 ADDITIONAL DC WIRES BETWEEN ROOM CONTROL AND SSP11.

FIGURE 4

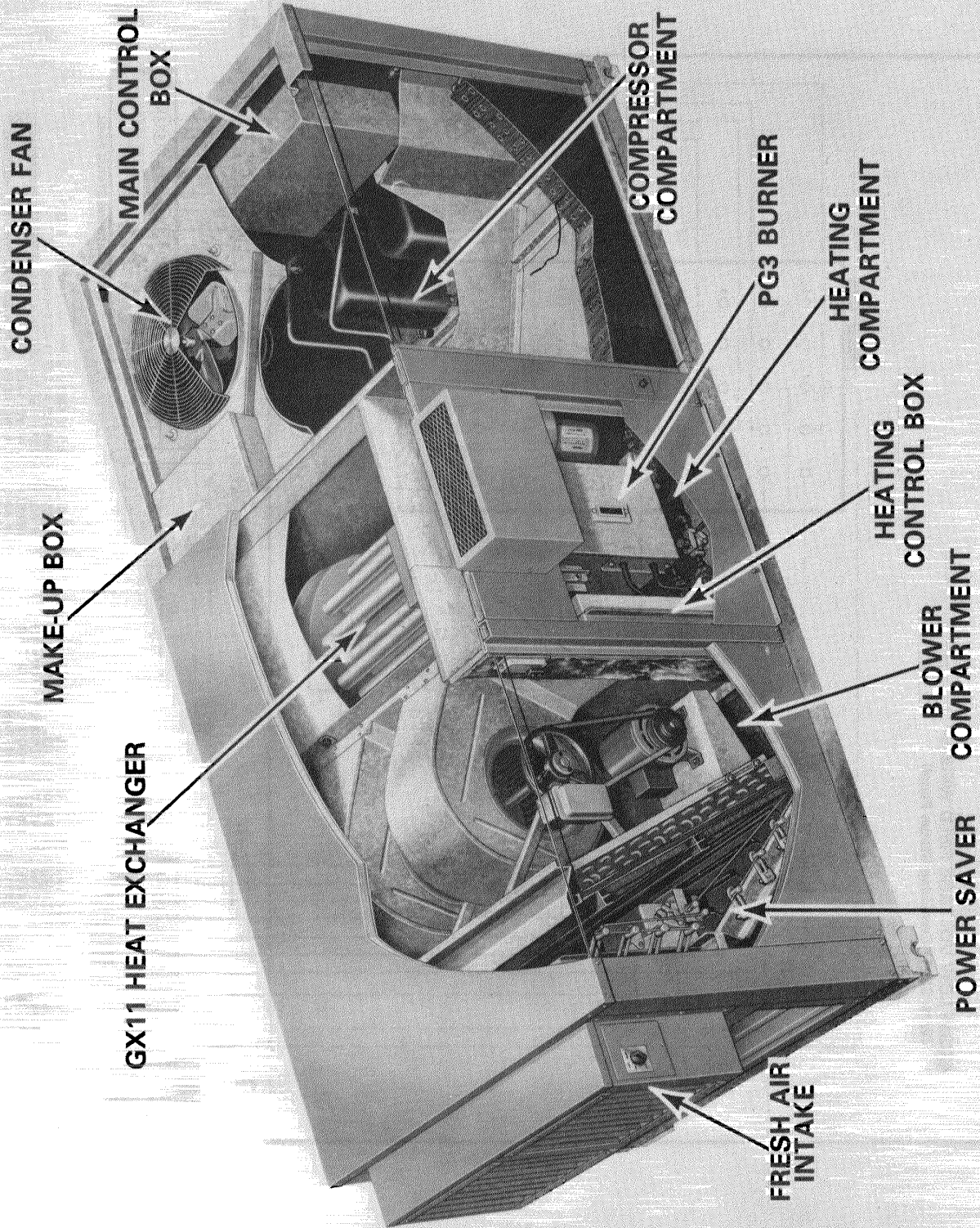

FIGURE 5

III - GCS11 COMPONENTS

Table 3 on Pages 17, 18 and 19 lists the GCS11 electrical components by their key numbers and then gives a brief description and general location. Figure 5 illustrates these general locations.

Table 3 also lists control setpoints (if applicable). Key number

labels are mounted next to each component for identification. Both the unit schematic diagram and the repair parts listing, key the components.

A - Main Control Box

Figure 6 identifies the components in the main control box. The K26 (heat readout relay) is only used on later production units.

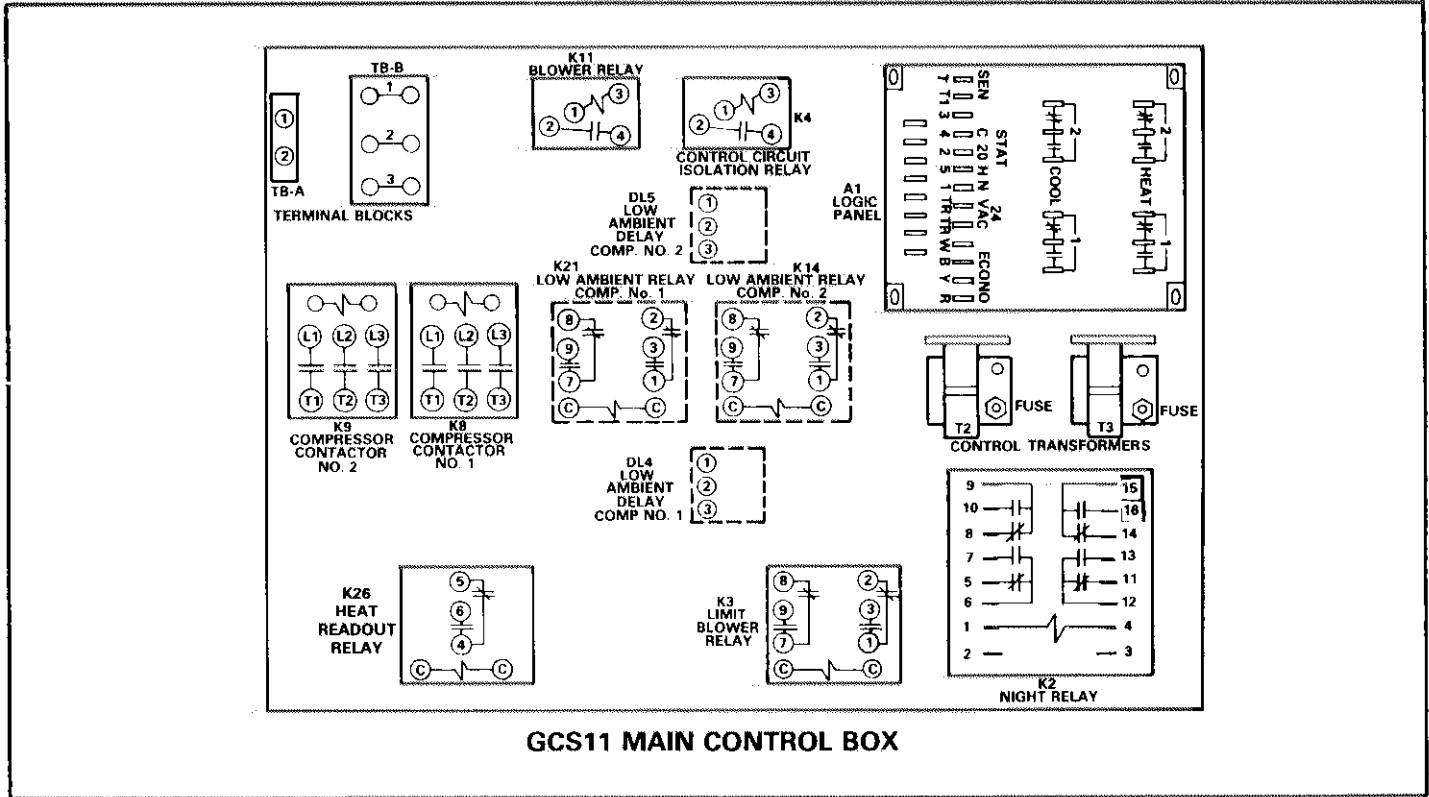

FIGURE 6

B - Make-up Box (Figure 7)

- 1 - Cooling Lockout Thermostat (S6)
S6 has an adjustable range from 20°F to 80°F. It is factory set at 55°F. Both compressors are locked out whenever the ambient temperature drops below set point.
- 2 - Low Voltage Terminal Block
Low voltage field wiring connects to this terminal block. The terminals are identified by both letters and numbers. The columns are labeled "C" through "G" and the rows are numbered 1 through 10. For example to find TBD-5, locate column labeled "D" and then go to row number 5. This terminal designation is used throughout the unit wiring diagram.

C - Compressor Compartment (Figures 8 & 9)

- 1 - Each compressor is protected with an internal line break overload. This device detects motor winding temperature to protect compressor from excessive heat and/or current draw. The compressors are also protected by an internal pressure relief valve which is set to open at a discharge and suction differential of 450 psig ± 50. In addition each compressor has an insertion type self regulating crank-case heater.
- 2 - Each refrigerant circuit includes high and low pressure switches for compressor protection. The high pressure

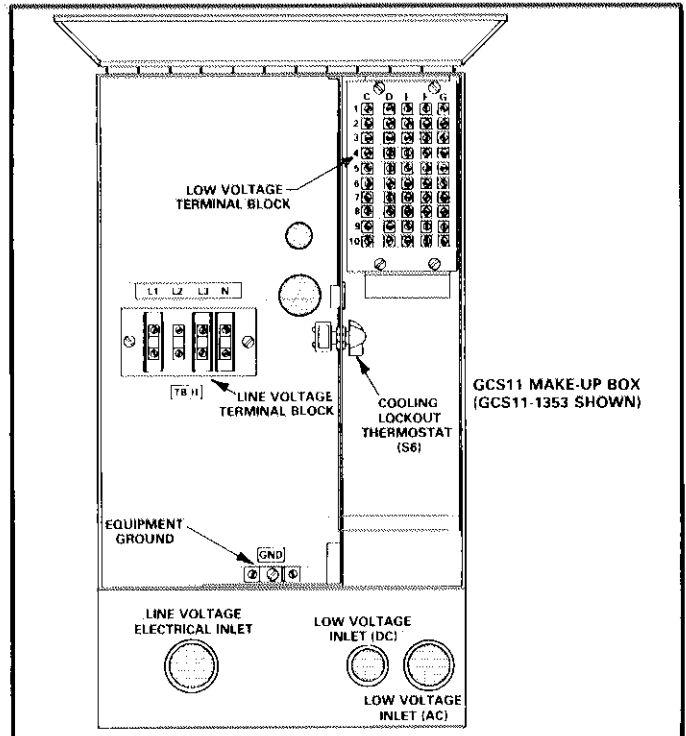

FIGURE 7

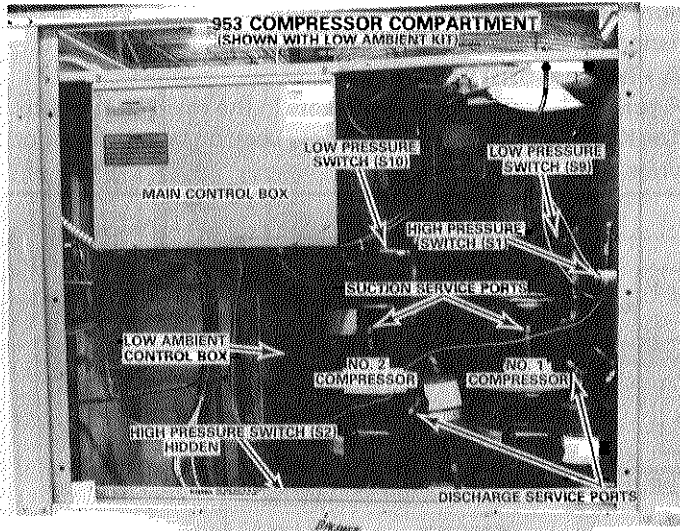

FIGURE 8

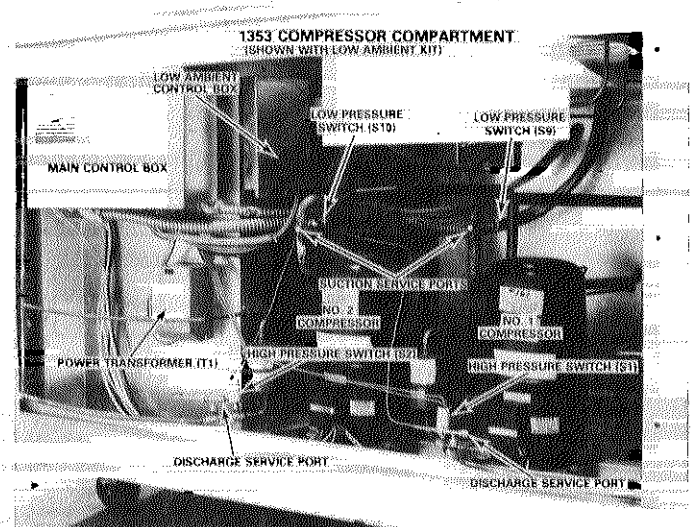

FIGURE 9

switch opens at 410 psig and must be manually reset. The low pressure switch cuts out compressor at 10 psig and automatically rests at 30 psig.

- 3 - The low ambient control box is a component within the Low Ambient Kit LB-37124B. Pressure switches within control box sense discharge pressure for each refrigerant circuit.
- 4 - The condenser fan draws air through the outdoor coil and discharges it out the top of unit. For fan service access, remove the bolts securing fan assembly. Figure 10 illustrates the condenser fan and motor assemblies.

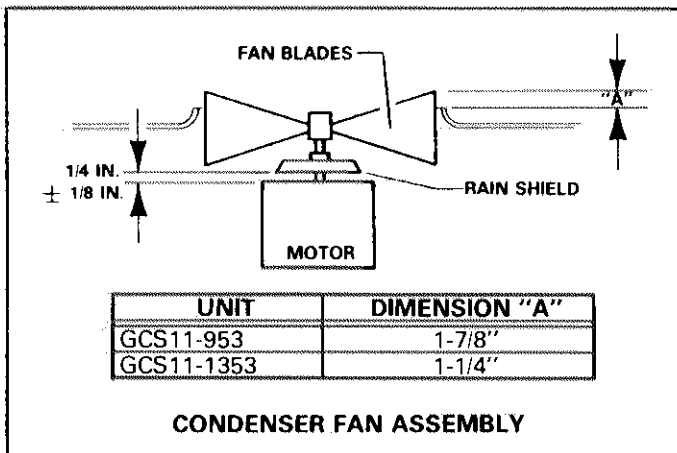

FIGURE 10

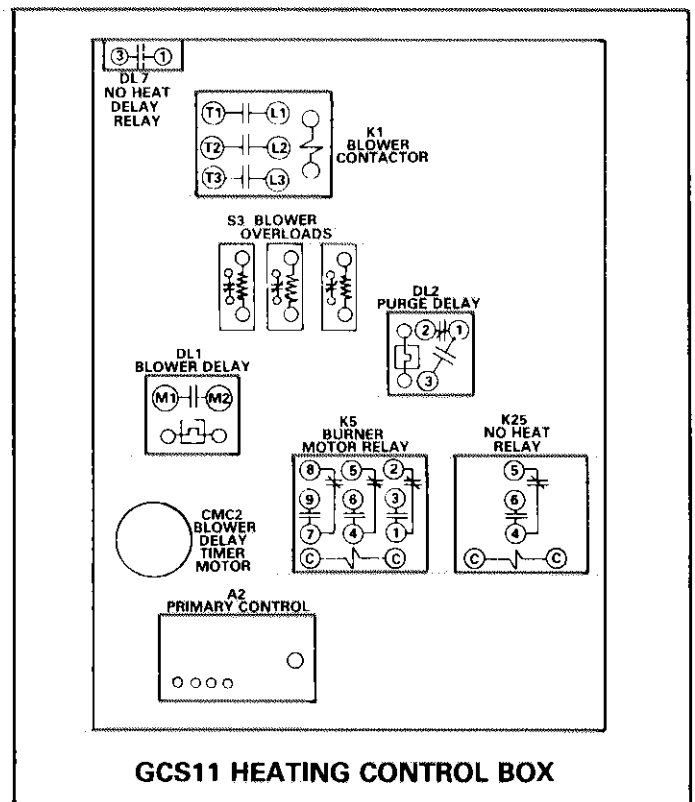
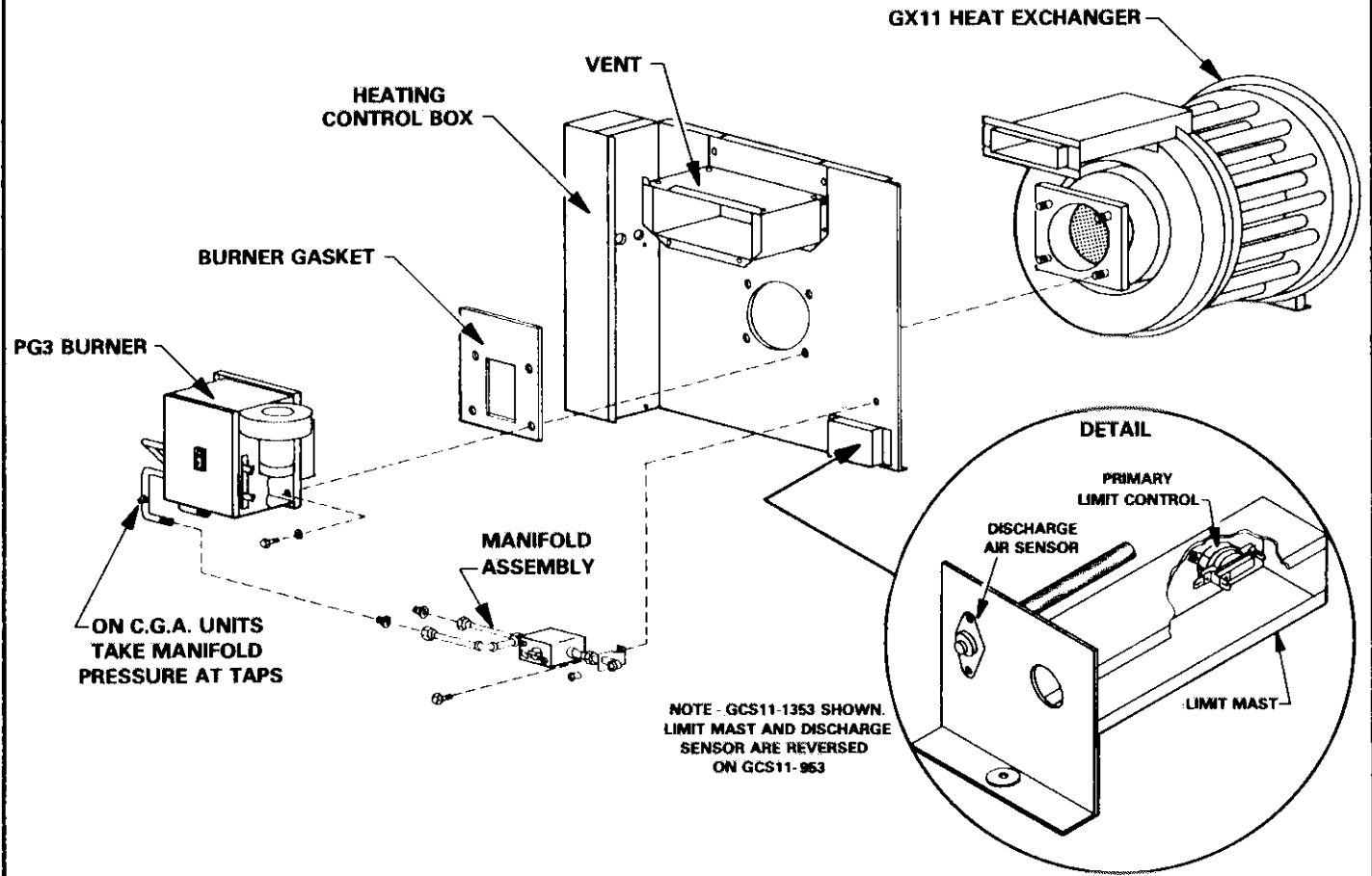

FIGURE 11

D - Heating Compartment

GCS11 units use the PG3 power burner. Basically the heating components provide fuel supply, combustion air supply, ignition source and proof of flame. Figure 12 identifies the heating compartment, Figure 11 shows the heating control box and Figure 13 illustrates the PG3 burner.

GCS11-953/1353 HEAT SECTION



A.G.A. MANIFOLD FOR PG3-175, PG3-130

A.G.A. MANIFOLD FOR PG3-145/250, PG3-195/330

C.G.A. MANIFOLD FOR PG3-145/250, PG3-195/330

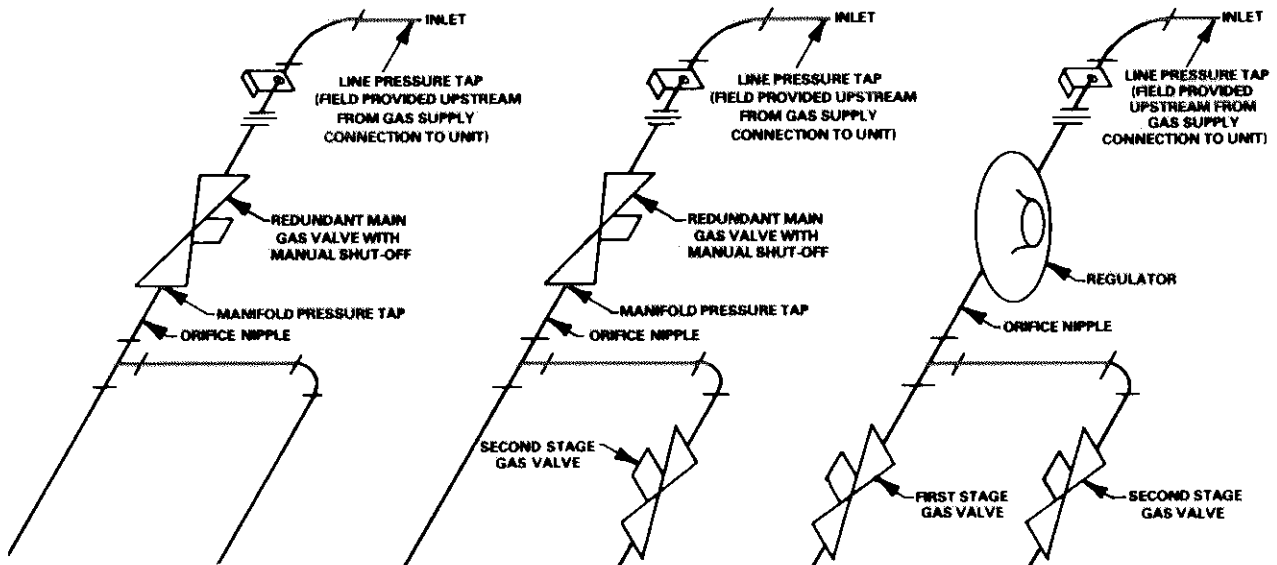

FIGURE 12

PG3 BURNER ASSEMBLY

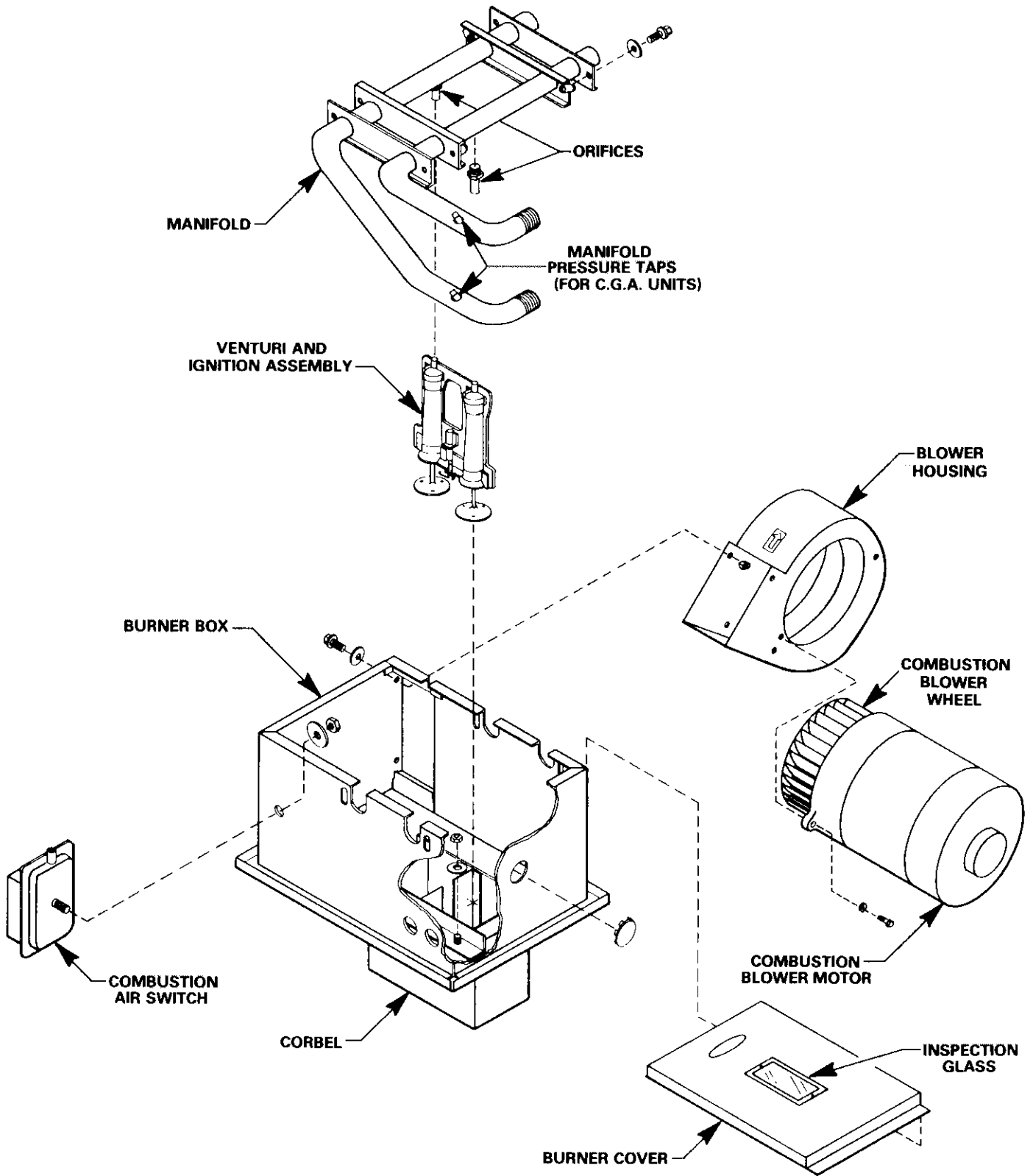

FIGURE 13

E - Blower Compartment (Figure 14)

- 1 - Table 2 lists the drive kit options.
- 2 - The indoor coil has two distinct stages. The top half is for the No. 2 refrigerant circuit, while the bottom half is for the No. 1 circuit. This is a draw through coil.
- 3 - The secondary limit control is located between the blowers.
- 4 - The optional time clock installs in the front of blower compartment.
- 5 - The filter switch (S14) used in the status panel option, installs at the side of blower housing.

TABLE 2

Model No.	Nominal Motor Hp	Maximum Usable Hp	Rpm Range Of All Available Drive Setups @ 1720 Rpm Motor Speed
GCS11-953	1-1/2	1.80	764 — 955
	3	3.45	994 — 1185
GCS11-1353	2	2.30	688 — 860
	3	3.45	894 — 1066

NOTE — Maximum usable hp of motors furnished by Lennox are shown in table. If other motors of comparable hp are used be sure to keep within the service factor limitations outlined on the motor nameplate. In Canada nominal horsepower is maximum usable horsepower.

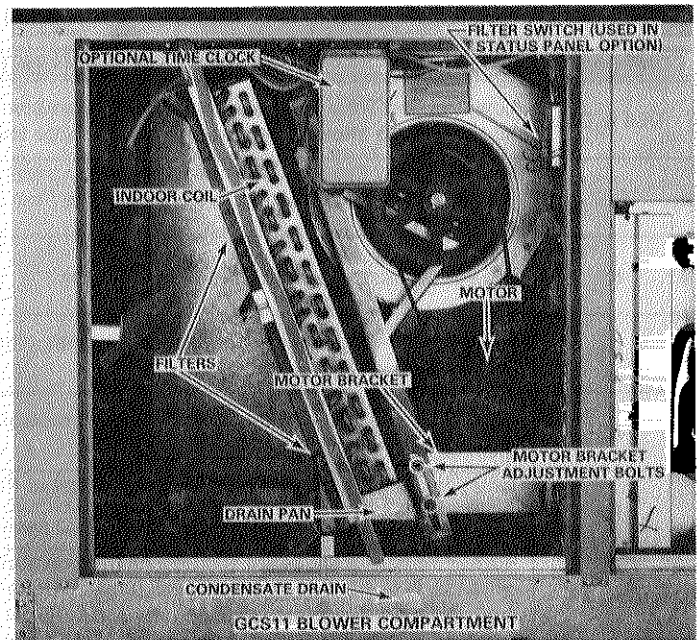

FIGURE 14

TABLE 3

COMPONENT	DESCRIPTION AND FUNCTION	LOCATION	SETTING
A1	Logic Panel — Receives the signal from room thermostat and balances this against the system output as determined by the discharge sensor; then initiates the heating or cooling modes as needed. Also modulates power saver closed with discharge temperatures between 62° and 50°F.	Main Control Box	---
A2	Primary Control — On a heating demand, as verified by the combustion air switch, A2 simultaneously energizes gas valve and provides ignition spark. If flame is not established, control locks out. If flame is lost during a duty cycle, A2 will retry for ignition once before locking out.	Heating Control Box	---
A3	Room Thermostat or Transmitter — Generates heating and cooling ramp signals based on the temperature deviation from the dual setpoint adjustments and a thermistor. Thermistor is internal to thermostat and remote to transmitter.	Remote	Adj. 55° — 85°
B1 & B2	Compressor No. 1 & No. 2 — Initiate DX cooling.	Compressor Compartment	---
B3	Indoor Blower Motor — Provides air supply through unit.	Blower Compartment	---
B4 & B5	Condenser Fan No. 1 & No. 2 — Draws air across outdoor coil for heat transfer in the refrigeration cycle.	Compressor Compartment	---
B6	Power Saver Motor — Used with the power saver option. Modulates outdoor dampers and return air dampers.	Power Saver	---
B8	Combustion Air Motor — Provides combustion air to the power burner.	PG3 Burner	---
C1 & C2	Capacitors — condenser fan.	Compressor Compartment	---
CR-2	Light Emitting Diode — Used in status panel circuit to show operating mode and failure.	Status Panel	---
CMC1	Clock Timer — Used in night setback option. 24 Hour skip-a-day clock programs a daily schedule. Any day or days can be omitted.	Blower Compartment	---
CMC2	Blower Delay Timer — Keeps the indoor blower motor operating approximately 3 minutes at the end of a heating or cooling cycle during periods of intermittent blower operation.	Heating Control Box	---
DL1	Blower Delay Relay — On a heating demand, DL1 energizes K3 limit blower relay to start blower motor during periods of intermittent operation.	Heating Control Box	On Time 5 to 30 Sec. Off Time 15-45 Sec.
DL2	Purge Delay Relay — DL2 is energized on a heating demand through its N.C. contacts. The "on time" delay permits a purge period to vent out combustion chamber before an ignition attempt is made.	Heating Control Box	On Time 25-55 Sec. Off Time 65-140 Sec.

TABLE 3

COMPONENT	DESCRIPTION AND FUNCTION	LOCATION	SETTING
DL4 & DL5	Low Ambient Time Delays — Used with low ambient option. Bypasses S9 or S10 for 30 seconds to allow compressor start-up under low ambient conditions.	Main Control Box	30 Sec.
DL7	No Heat Delay Relay — This solid state delay provides a 180 second time period at the beginning of a heating cycle before the "no heat" circuit to status panel is energized.	Main Control Box	180 Sec.
K1	Blower Contactor — Energizes blower motor.	Heating Control Box	---
K2	Night Relay — Activates the night setback mode when optional clock timer contacts make.	Main Control Box	---
K3	Limit Blower Relay — Energizes K1 to start blower motor. When de-energized, it drives power saver motor B6 closed.	Main Control Box	---
K4	Isolation Relay (not used with Switching Status Panel) — This relay isolates the "Fan switch" function within a single control circuit. When K4 is energized, the N.O. K4-1 contacts close to then energize K3 and consequently bring on the blower motor.	Main Control Box	---
K5	Burner Relay — K5 is energized on a heating demand through DL2 purge relay N.C. contacts. N.O. K5-3 contacts close to latch in the relay until the heating demand is over. N.O. K5-1 contacts close to energize B8 combustion air motor. N.O. K5-2 contacts also close to permit an ignition attempt after DL2 N.O. contacts make.	Heating Control Box	---
K8	No. 1 Compressor Contactor — Energizes compressor B1 and condenser fan B4 on demand.	Main Control Box	---
K9	No. 2 Compressor Contactor — Energizes compressor B2 and condenser fan B5 on demand.	Main Control Box	---
K11	Blower Relay — K11 is energized on a cooling demand. N.O. K11-1 contacts close to then energize K3. K3 brings on blower motor.	Main Control Box	---
K14	Low Ambient No. 2 Relay (optional) — Used in low ambient applications, this relay is energized with K9. It latches itself in to bypass S10 and allow a compressor start-up. After DL5 times out (30 seconds), this circuit opens and S10 is again brought into the control circuit.	Main Control Box	---
K21	Low Ambient No. 1 Relay (optional) — Used in low ambient applications. This relay is energized with K8. It latches itself in to bypass S9 and allow a compressor start-up. After DL4 times out (30 seconds), this circuit opens and S9 is again in the control circuit.	Main Control Box	---
K23	Voltage Controlled Relay — Used only with switching subbase or switching status panel and power saver. It opens on a 2.5V-3V dc signal. When made it energizes K3 to bring on blower motor.	Field Installed	---
K25	No Heat Relay — K25 is energized with the gas valve on a heating demand. It is used in the status panel circuit as proof of heat.	Heating Control Box	---
K26	Heat Readout Relay — Isolates heating readout function from heating control circuit. Used only on later production units.	Main Control Box	---
	Humid Climate Option — This field provided and field installed relay eliminates power saver operation during excessive humidity conditions.	Field Installed	---
R1	Night Heating Operation Resistor — Used in night setback option to determine degree of heating setback.	Make-up Box	(5°, 10° or 15°F)
R2	Night Cool Setup Resistor — Used in night setback option to determine degree of cooling setup.	Make-up Box	(5°, 7°, 9°, 10°, 13°, 15°F or cooling lockout)
RT1	Discharge Sensor — Sends a dc current voltage to logic panel which is equivalent to the discharge temperature.	Heating Compartment	---
RT2	Remote Room Sensor (optional) — This is the thermistor that is used with the room transmitter option.	Remote	---
S1	No. 1 High Pressure Switch — Shuts off compressor (B1) control circuit when refrigerant pressure rises above setting. Must be manually reset.	Compressor Compartment	410 psig Out
S2	No. 2 High Pressure Switch — Shuts off compressor (B2) control circuit when refrigerant pressure rises above setting. Must be manually reset.	Compressor Compartment	410 psig Out
S4	Primary Limit — At excessive unit temperatures S4 de-energizes heating control circuit. In addition it also keeps K3 energized to maintain blower operation until control resets.	Heating Compartment	953 150°F Out 115°F In 1353 160°F Out 115° In

TABLE 3

COMPONENT	DESCRIPTION AND FUNCTION	LOCATION	SETTING
S5	Secondary Limit — This added limit also de-energizes heating control circuit at excessive unit temperatures. It also keeps K3 energized to maintain blower operation until control resets.	Blower Compartment	150°F Out 115°F In
S6	Cooling Lockout Thermostat — Shuts off all cooling compressor operation when ambient temperature drops below setting. Factory set at 55°F.	Make-up Box	Adj. 20° to 80°F
S7	Combustion Air Switch — S7 must close before primary control can be energized. Assures combustion chamber purge and presence of combustion air.	PG3 Burner	---
S9	No. 1 Low Pressure Switch — Shuts off compressor (B1) control circuit when suction pressure drops below setpoint. Automatically resets	Compressor Compartment	30 psig In 10 psig Out
S10	No. 2 Low Pressure Switch — Shuts off compressor (B2) control circuit when suction pressure drops below setpoint. Automatically resets.	Compressor Compartment	30 psig In 10 psig Out
S13	Enthalpy Control (Used with power saver) — Senses heat content of outside air. When heat content rises above setpoint, control switches to close outdoor dampers to minimum position.	Fresh Air Intake	“A” Adj.
S14	Filter Switch — Used with optional status panel. Indicates restricted air flow through the filters.	Blower Compartment	---
S15	No. 1 Low Ambient Pressure Switch — Used with low ambient option. Shuts off condenser fan (B4) when head pressure drops below setting.	Main Control Box	250 psig Out 290 psig In
S16	No. 2 Low Ambient Pressure Switch — Used with low ambient option. Shuts off condenser fan (B5) when head pressure drops below setting.	Main Control Box	250 psig Out 290 psig In
T1	Power Transformer — On 460V & 575V units, T1 drops line voltage to 220V for the control circuit voltages. (200V & 230V).	Compressor Compartment	---
T2	Control Transformer — Provides 24V power to the control circuit.	Main Control Box	---
T3	Thermostat Transformer — Provides 24V power to thermostat circuit.	Main Control Box	---
T4	Power Saver Transformer — Provides 24 volts to power saver motor (B6). Has multi-tap leads to choose between 200V & 230V input when field installing.	Power Saver	---
TB-A	High Voltage Terminal Block — 3 Phase line voltage.	Main Control Box	---
TB-B	High Voltage Terminal Block — 1 Phase 230V control voltage.	Main Control Box	---
TB-C, D,E,F&G	Low Voltage Terminal Block	Make-up Box	---

IV - REFRIGERANT SYSTEM

Two compressors are used in separate refrigerant circuits. Each system uses an expansion valve to meter the refrigerant.

Each unit is furnished with a normal operating pressure curve. The curve utilizes suction pressure, discharge pressure and outdoor temperature comparison. To use the chart, first check suction pressure, then move over to the outdoor temperature and finally down to the discharge pressure. If the discharge pressure is within five pounds of this reading, the unit is properly charged, providing the three conditions meet in the unshaded area of the chart. If they meet in the shaded area, there is something wrong with the system and further checks are needed. Always replace access panels and seal around gauge hoses when monitoring refrigerant pressures.

V - GCS11 HEATING SYSTEM

A - A.G.A./C.G.A. Usage

All A.G.A. units use a redundant main gas valve with a reg-

ulating feature. This is true for both natural gas and L.P. gas applications. The redundancy feature assures gas shut off in the event one solenoid sticks open. This main valve is the first stage. A separate second stage valve is used in two stage applications. The PG3-175 and PG3-230 burners are only A.G.A. approved.

C.G.A. units use a separate regulator with two gas valves. A manual main gas valve is sent with unit for field installation.

B - Gas Piping

Before connecting piping, check with gas company or authorities having jurisdiction for local codes or requirements. A manual main shut off valve and union should be installed in gas line external to unit. Union must be of the ground joint type. See Figure 15. Installer must also provide a 1/8 inch N.P.T. plugged tap in field piping. Tap must be accessible for test gauge connection. A drip leg must be installed on all vertical pipe runs.

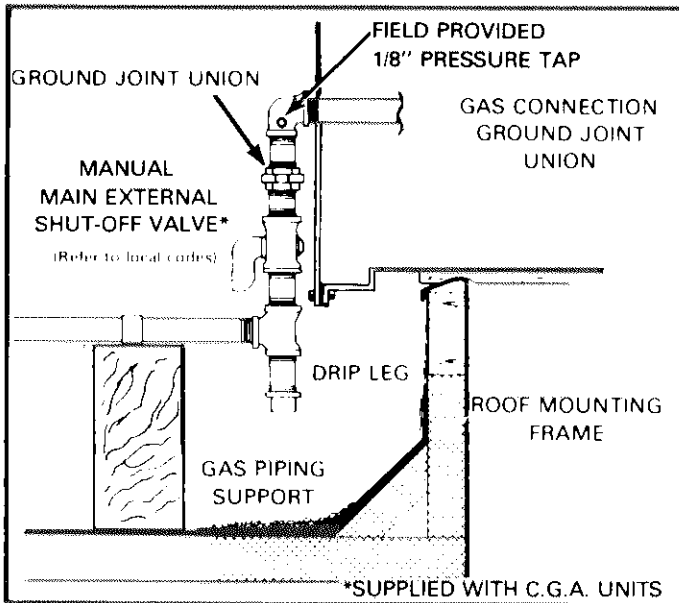

FIGURE 15

C - PG3 Power Burner

The PG3 burner is available in four sizes as indicated in the burner rating table on page 5. The PG3-175 and PG3-230 models are characterized by a low temperature rise. The PG3-250/145 and PG3-330/195 models are two staged.

The 1/10 H.P. combustion blower motor provides air for combustion. It prepurges heat exchanger (through DL2 and proving circuit) before ignition trial period. The venturi mixes air and gas in correct proportion for proper combustion. The fuel mixture is ignited by sparking at the electrodes which is initiated by the primary control. The flame spreader fits flame to combustion chamber for uniform heat distribution. The flame rod monitors flame condition in conjunction with the primary control. The burner has an inspection window to view flame.

D - LP Conversion Kits

All A.G.A. PG3 burners are factory shipped in the GCS11 for natural gas only. However, LP changeover kits are available for the PG3-250/145 and PG3-330/195 size burners. See Table 4. PG3-175 and PG3-230 size burners are only A.G.A. approved for natural gas. Basically the LP kit consists of two burner orifices, a manifold inline orifice nipple and a regulator conversion kit for the main gas valve.

All C.G.A. units are shipped to the field with LP components installed.

TABLE 4

PG3 Burner	Kit Number	Burner Orifice Size	Orifice Nipple Size
PG3-250/145	LB-39477CA	#22	"E"
PG3-330/195	LB-39477CB	#15	"L"

E - High Altitude Derate

On A.G.A. burners it may be necessary to derate the unit. If the heating value of the gas does not exceed values listed in Table 5, derating is not required. Should the heating value of

the gas exceed the table values, or if the elevation is greater than 6,000 feet above sea level, it will be necessary to derate the unit. Lennox requires that derate be based on 4% per thousand feet above sea level. Thus at an altitude of 4,000 feet, if the heating value of the gas exceeds 1,000 Btu/ft³, unit will require a 16% derate. Table 6 lists the existing PG3 orifices for A.G.A. burners.

All C.G.A. units are shipped to the field derated for altitude.

TABLE 5

Elevation Above Sea Level (Feet)	Maximum Heating Value (Btu/ft ³)
5001 — 6000	900
4001 — 5000	950
3001 — 4000	1000
2001 — 3000	1050
Sea Level — 2000	1100

TABLE 6

PG3 Burner	Orifice Drill Size	
	Burner Orifice	Nipple Orifice
PG3-175	#9	----
PG3-250	#3	----
PG3-250/145	"F"	"V"
PG3-330/195	"K"	1/2"

F - GX11 Heat Exchanger

The GX11 heat exchanger has a flame observation port located at the rear of heat exchanger. For access remove the rear heating access panel. Heat exchanger condensate connections are provided on both sides of unit. Condensate must be routed away from heat exchanger.

If it should be necessary to clean the flue gas passageways, use the following steps:

- 1 - Remove the heat exchanger rear access panel.
- 2 - Unscrew cap screws and remove heat exchanger breeching. See Figure 16.
- 3 - Slide flue baffles from heat exchanger tubes.
- 4 - Clean flue passageways with a wire brush.
- 5 - Replace gasket and reassemble heat exchanger.

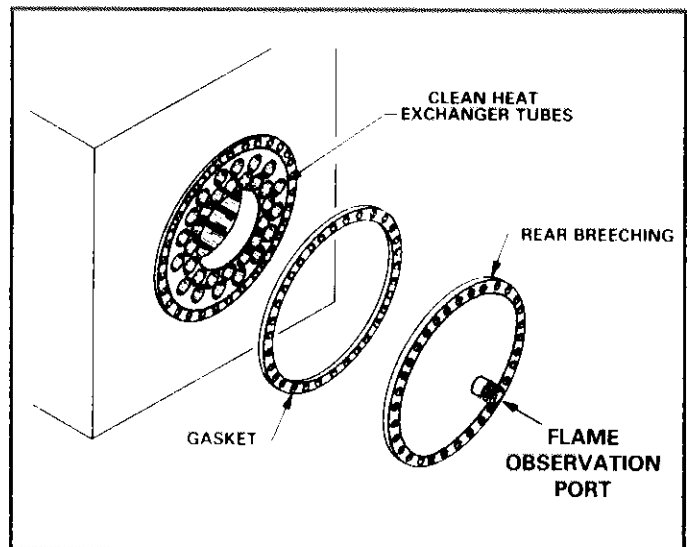

FIGURE 16

G - Primary Control

A Fenwal direct spark ignitor system (style O5-16) is used in GCS11 units. On a heating demand, as verified by the combustion air switch, voltage is applied to the ignitor across terminals 1 (power) and 6 (ground). A high voltage spark is then generated from the spark electrode to ground. The primary control simultaneously opens the 24V gas valve. As soon as the flame is established, the sparking stops. An electronic flame sensing circuit consisting of the flame rod and the primary control detects the burner flame. If the flame is not established during the ignition tryout period (6.8 seconds), the control closes the gas valve and locks out. If there is flame outage during the duty cycle, the primary control will retry for ignition once before going into lockout. The heating demand must be broken before control will reset. To re-establish trial for ignition after lockout, move the room thermostat heating lever below the room temperature and then back to desired setpoint. Figure 17 shows the primary control.

Electrode setting must be maintained at 1/8 inch. Figure 18 shows the PG3 venturi and ignition assembly. Note that on two stage burners the top half is low fire and the bottom half is high fire.

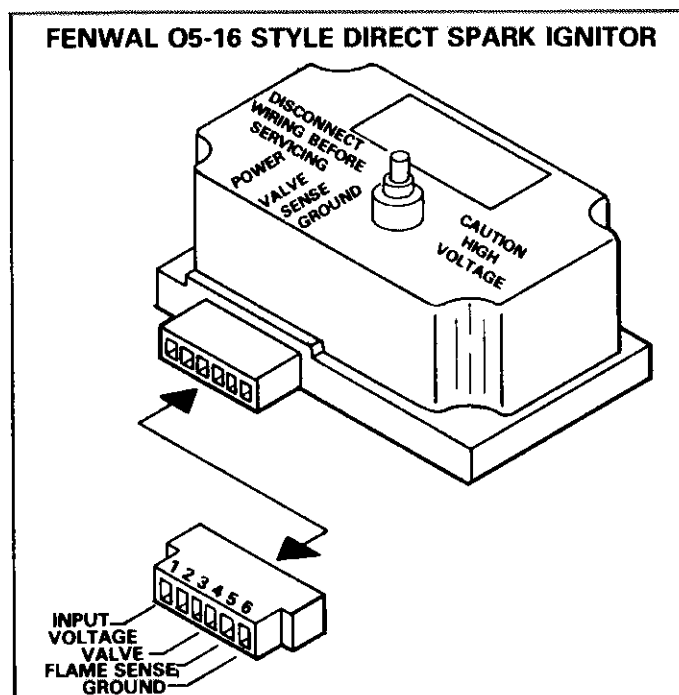

FIGURE 17

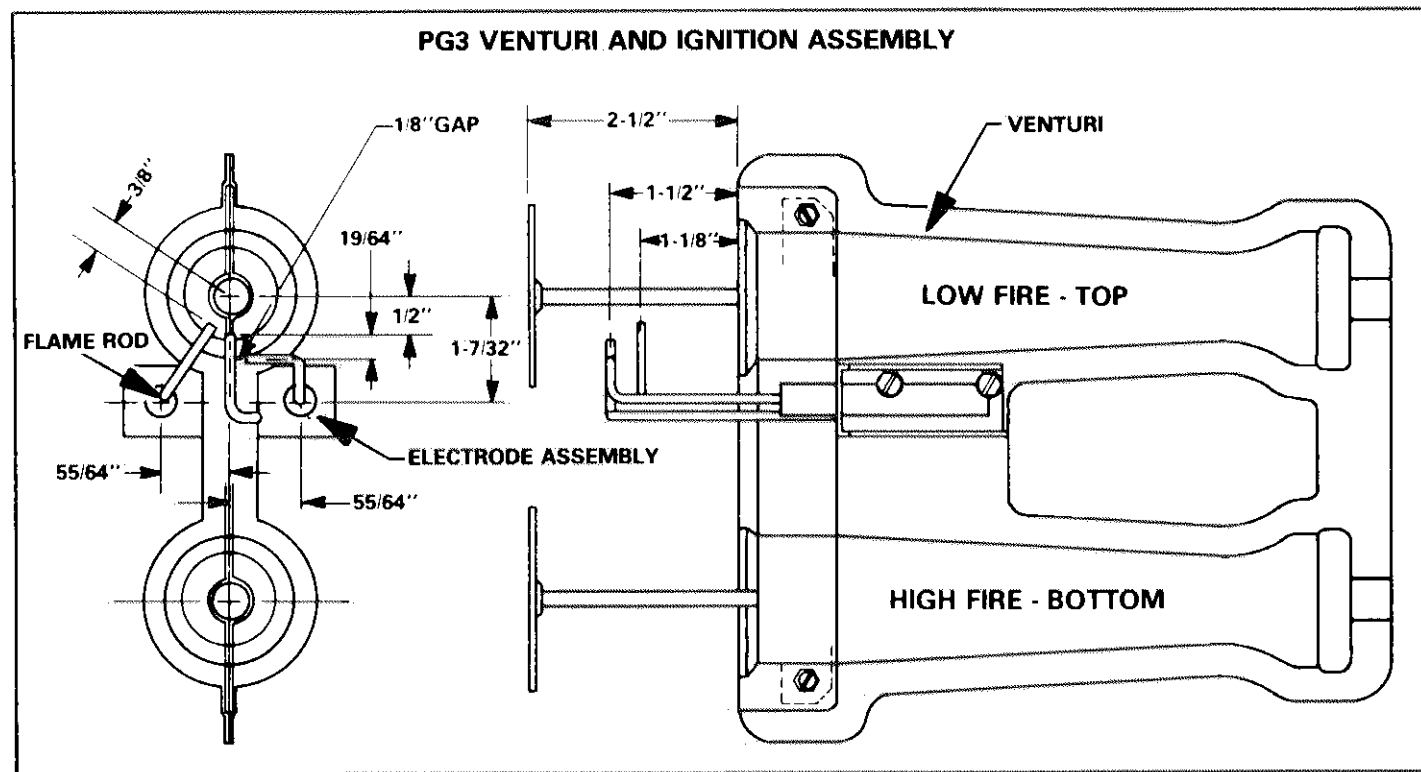

FIGURE 18

H - Start-Up And Shut Down Procedures

1 - Start-Up

Close manual knob on gas valve. Set room thermostat to lowest setting. Wait at least 5 minutes and then open manual knob on gas valve. Set room thermostat to desired temperature. If a switching subbase or switching status panel is used, be sure the system switch is set to

"Heat." On a heating demand the burner should ignite. If it does not, repeat preceding steps.

2 - Safety Shutdown

Turn off power to unit. Close manual knob on gas valve. DO NOT ATTEMPT TO RELIGHT BURNER WITH A HOT COMBUSTION CHAMBER. Wait a minimum of 5 minutes to allow heat exchanger time to purge unburned gases before trying to restart.

3 - Extended Period Shutdown

To shutdown unit for an extended period of time, set thermostat at lowest setting and turn off power to unit. Close all gas valves both internal and external to unit to guarantee no gas leak into combustion chamber. All access panels, covers and vent caps must be in place and secured. Refer to step 1 to reactivate unit.

I - Gas Pressure Adjustment

- 1 - Check gas line pressure with unit firing at maximum rate. A minimum of 6 inches w.c. for natural gas or 10 inches w.c. for LP gases should be maintained. On multiple unit installations, check each unit in sequence, beginning with the one closest to the supply gas main and progressing to the one furthest from the main. Line pressure should be a nominal 7 inches w.c. for natural gas or a nominal 11 inches w.c. for LP gas with all units firing on high stage.
- 2 - After line pressure has been checked and adjusted, check manifold pressure during high fire operation. Refer to Figure 19 for location to take readings. The readings must correspond to Table 7.

TABLE 7

	UNIT	NATURAL GAS	L.P. GASES
A.G.A.	GCS11-953	4.0	9.0
	GCS11-1353	4.0	9.0
C.G.A.	GCS11-953	3.1	5.3
	GCS11-1353	3.0	6.3

- 3 - To check for proper gas flow to combustion chamber, determine the Btuh input from the GCS11 rating plate. Divide this input rating by the Btuh per cubic foot of available gas. This is the number of cubic feet of gas required per hour. Next determine the flow of gas through gas meter for 2 minutes and multiply by 30 to calculate the actual gas flow to burner. Gas input should not exceed burner rating. If it does, make necessary adjustments.

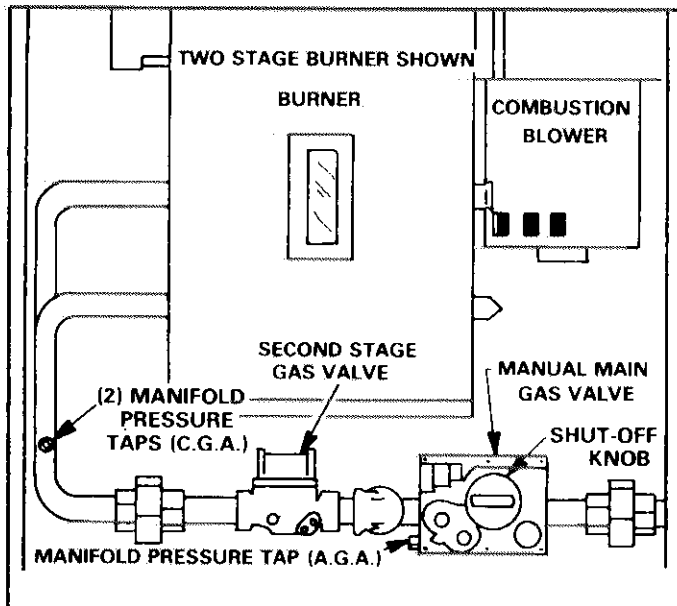

FIGURE 19

J - Burner Flame

The natural gas flame is totally blue. The LP gas flame is basically blue, but may have slight clear yellow streaking. Figure 20 shows the burner flame.

The combustion air is factory set for normal operation. Minor changes in the air adjustment may be necessary to compensate for the heating value of the gas. A combustion air adjustment lever is provided on combustion blower. Loosen lockscrew and move lever to desired position. See Figure 21.

For efficient operation keep combustion air blower wheel clean. Remove combustion air blower assembly and clean wheel blades with a small brush.

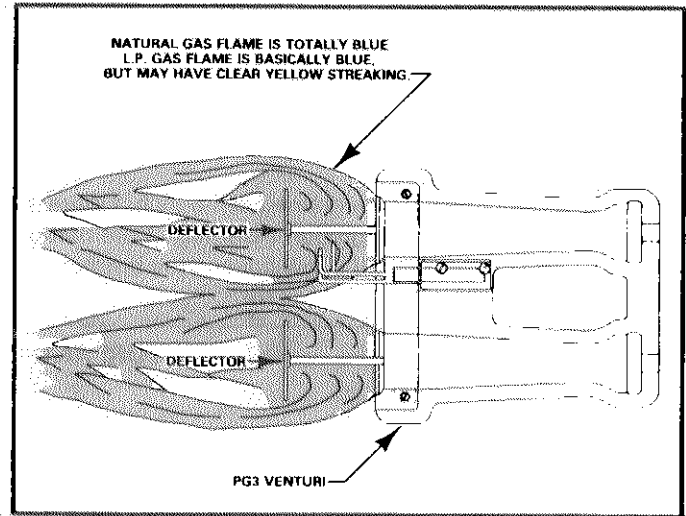

FIGURE 20

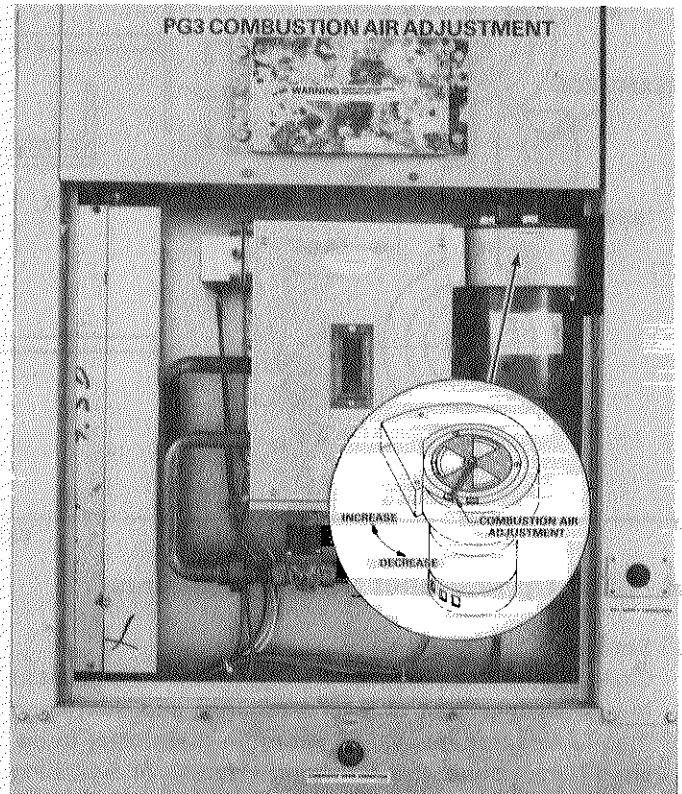

FIGURE 21

VI - BLOWER OPERATION AND ADJUSTMENTS

A - Blower Operation

- Units with standard room control subbase:
Blower operates continuously in normal operation. Units with optional night operation controls will have intermittent blower operation during night control period.
- Units with switching subbase or switching status panel:
Blower operation is manually set at the fan switch. In "ON" position the blower operates continuously. Intermittent blower will only occur if optional night operation controls are installed. During night operation the blowers will cycle with demand.

With fan switch set in "Auto", the blower cycles with demand. If the application includes power saver, a field installed K23 Voltage Controlled Relay picks up blower for power saver operation.

Blower operation drops out when system switch is set at "Off".

B - Determining Unit CFM

- The following measurements must be made with a dry indoor coil. Run blower without a heating or cooling demand. The air filters must be in place while taking measurements.
- Measure static pressure external to unit.
- Measure the indoor blower motor RPM.
- Refer to Blower Performance Chart. Use the static pressure and RPM readings to determine unit CFM.
- The CFM can be adjusted at the motor pulley. Loosen the allen screw, and then turn adjustable sheave clockwise to increase CFM or counter-clockwise to decrease CFM. See Figure 22.

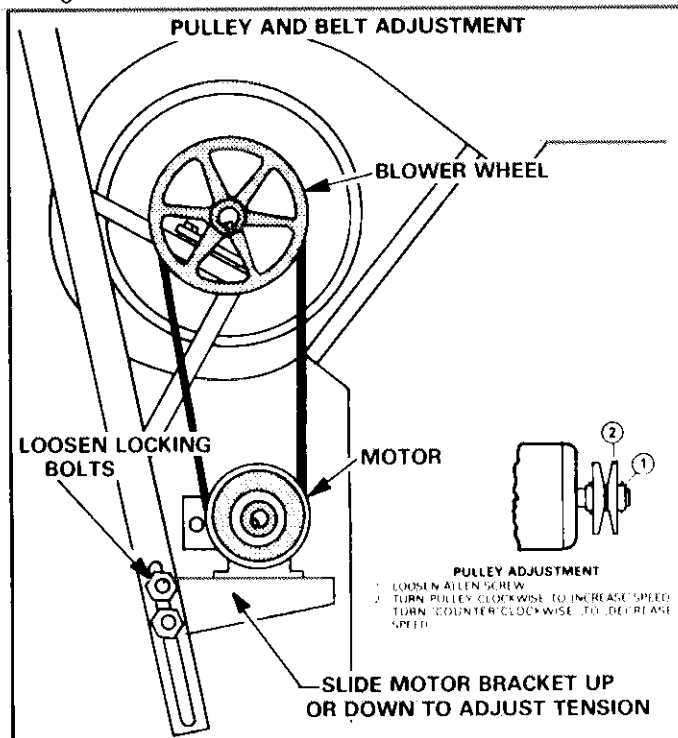

FIGURE 22

C - Blower Belt Adjustment

Maximum life and wear can be obtained from the belt only if proper pulley alignment and belt tension are maintained. Initially, tension new belt after a run in period of 24-48 hours. This allows belt to stretch and seat in the grooves. To adjust belt tension, loosen 4 locking bolts and slide motor bracket up or down. See Figure 22.

VII - THERMOSTAT OR TRANSMITTER OPERATION

A room control installed with a standard subbase allows only heating and cooling setpoint adjustment. The temperature gap between the setpoint levers represents the "no load" band where no heating or cooling can occur. With levers positioned side by side, the no load band is 3°F. With levers wide apart, the no load band is 30°F.

A room control installed with an optional switching subbase or optional switching status panel will allow heating and cooling setpoint adjustment, system function selection and blower operating control. The system function switch is manually set for the desired operation mode:

- HEAT — Heat only
- COOL — Cooling only.
- AUTO — System automatically provides heating or cooling on demand.
- OFF — System off.

The fan switch manually sets to desired position:

- AUTO — Blower cycles with demand.
- ON — Blower runs continuously.

VIII - GCS11 UNIT OPTIONS

A - Power Saver (Figure 23)

- The power saver motor modulates in response to the cooling ramp signal, discharge low limit feature, and enthalpy control setting. The range is 1.5 to 4VDC. The out-

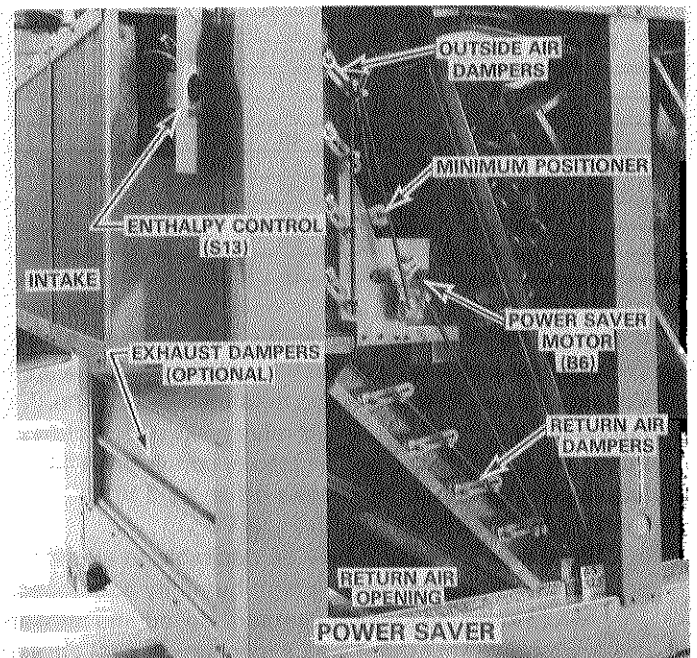

FIGURE 23

side dampers are in minimum position at 1.5 volts and are open at 4 volts.

- 2 - The enthalpy control is located in the outdoor air inlet of unit. It senses the total heat content of the outside air including latent heat. If the heat content rises above control setpoint, the power saver dampers drive to minimum position. The recommended set point is "A" as shown in Chart A. If power saver is allowing air which is too warm or humid to enter system, set control to a lower setpoint. Refer to Chart A.
- 3 - The power saver motor includes a spring return feature which closes motor on a power failure. The motor stroke is 160 degrees as shown in Figure 24 and the timing is 40 seconds. With R-W terminals shorted or B leg open, the motor drives outside dampers closed. With R-B terminals shorted or W leg open, the motor drives outside dampers open.
- 4 - Dampers are factory adjusted. The dampers rotate 90 degrees. If adjustment is needed, drive the dampers closed and adjust each blade individually.
- 5 - Adjust minimum positioner with outside dampers at minimum position (turn enthalpy control to "D"). Rotate screw clockwise to open dampers or counterclockwise to close dampers. Table 8 lists the percentage of fresh air per damper blade dimension opening. Return enthalpy control back to normal setting.

If desired a remote minimum positioner may be used in place of the one at motor bracket. Simply disconnect existing minimum positioner and wire the new one with "W" lead to TBE-7 and "R" lead to TBE-8. The remote minimum positioner rotates counter-clockwise to open and clockwise to close.

TABLE 8

Damper Blade Angle	FRESH AIR PERCENTAGE (%)					
	Return Air Duct Static Pressure					
	0" (0mm)		.25" (6mm)		.5" (13mm)	
	PSD11	OAD11	PSD11	OAD11	PSD11	OAD11
5°	13%	12%	20%	18%	30%	27%
10°	26	21	34	27	46	37
15°	37	27	46	33	57	41
20°	48	31	57	37	66	43
25°	58	34	66	38	74	44
30°	69	37	75	41	81	45
35°	79	40	84	43	88	46
40°	90	45	92	46	94	47

- 6 - If the GCS11 application includes power saver and a switching subbase or a switching status panel, a K23 Voltage Control Relay must be field installed. When the fan switch is set at "Auto", this relay picks up the blower for power saver operation. The blower comes on at 4 VDC (cooling ramp signal) and cycles off at 2.5-3 VDC.

- 7 - Humid Climate Option:
In very humid climates it may be desirable to eliminate power saver operation during high humidity conditions. This would keep the outside dampers closed and blower motor stopped until there was a mechanical cooling demand. On a mechanical cooling demand, the outside

CHART A

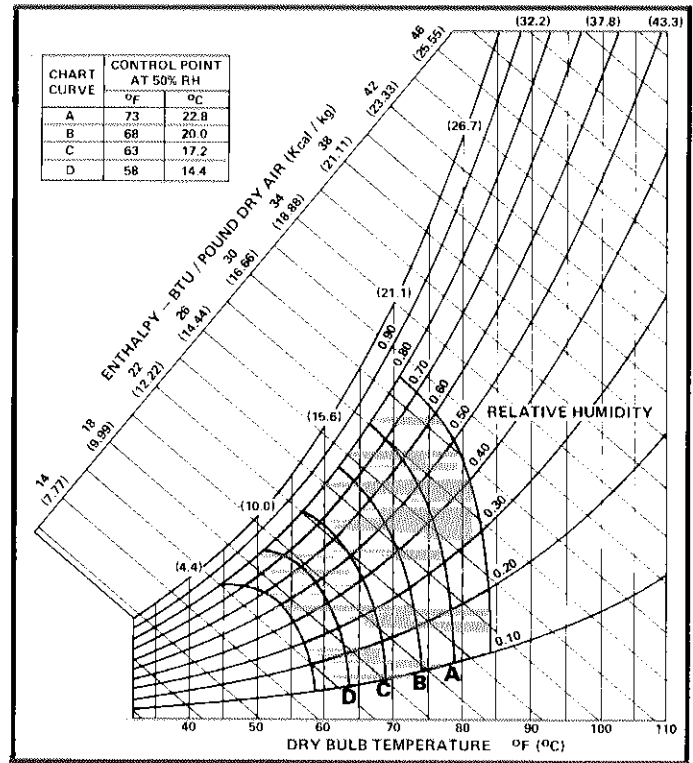

dampers would open to minimum position for ventilation and the blower would run. During favorable conditions the power saver would function normally.

This can be accomplished with the use of a switching subbase or switching status panel and the field installation of a special relay. Figure 25 shows the hook-up and explains the sequence of operation.

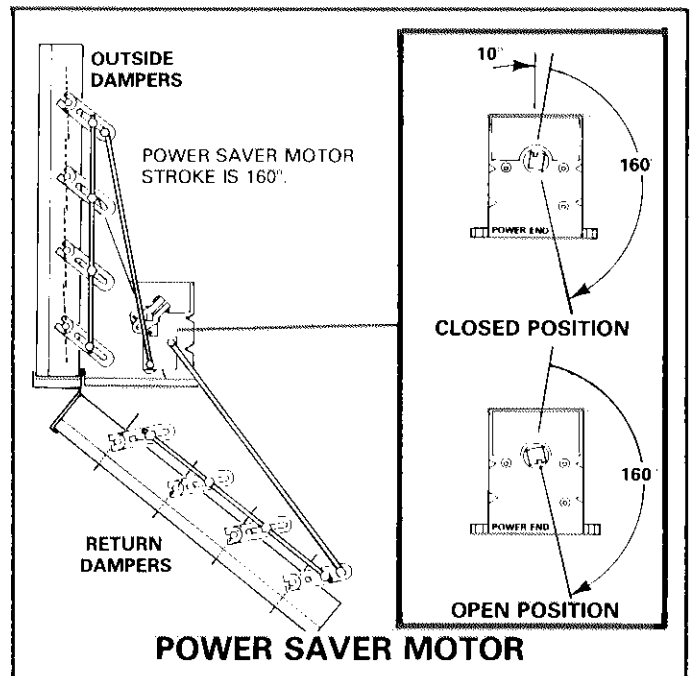

FIGURE 24

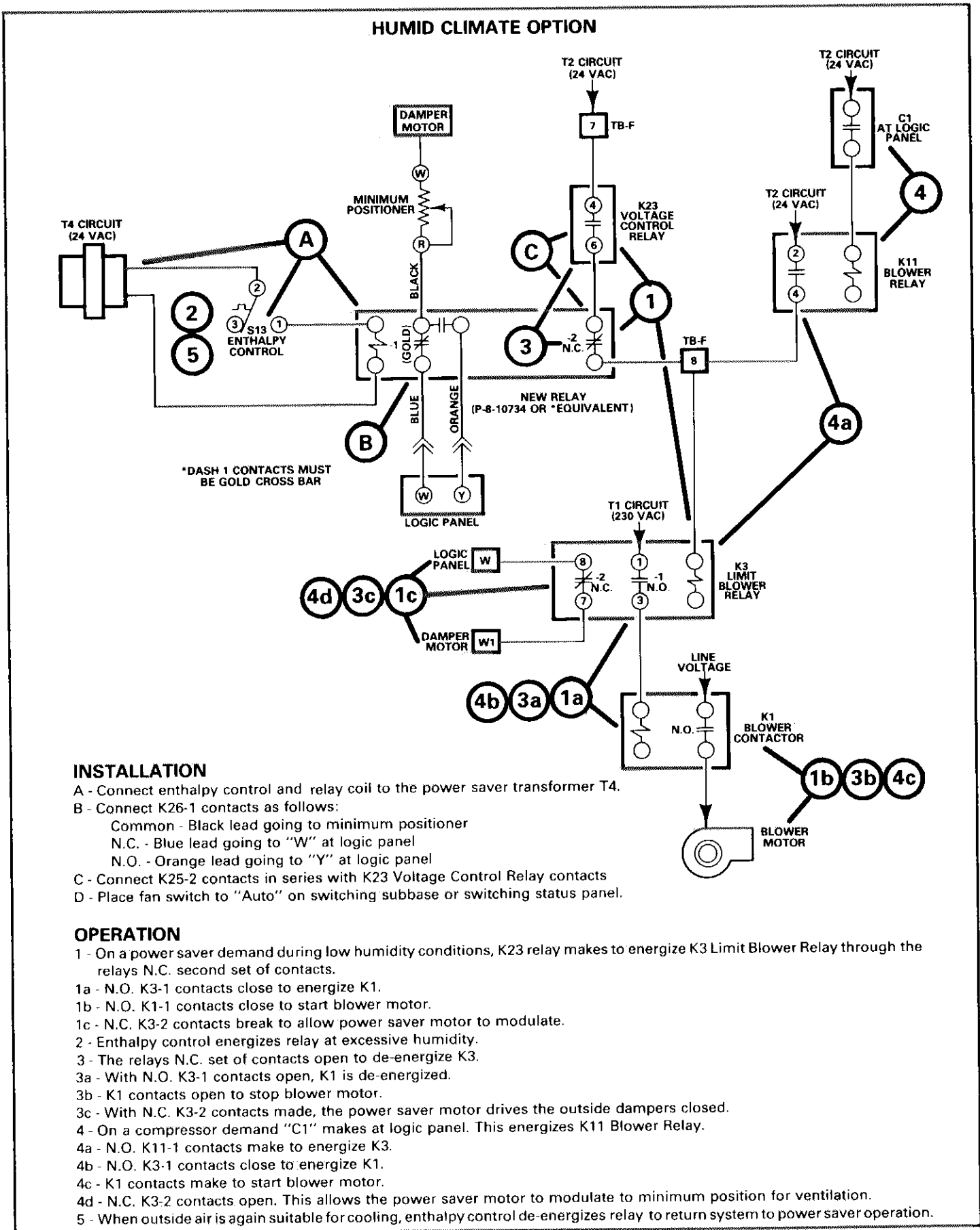

FIGURE 25

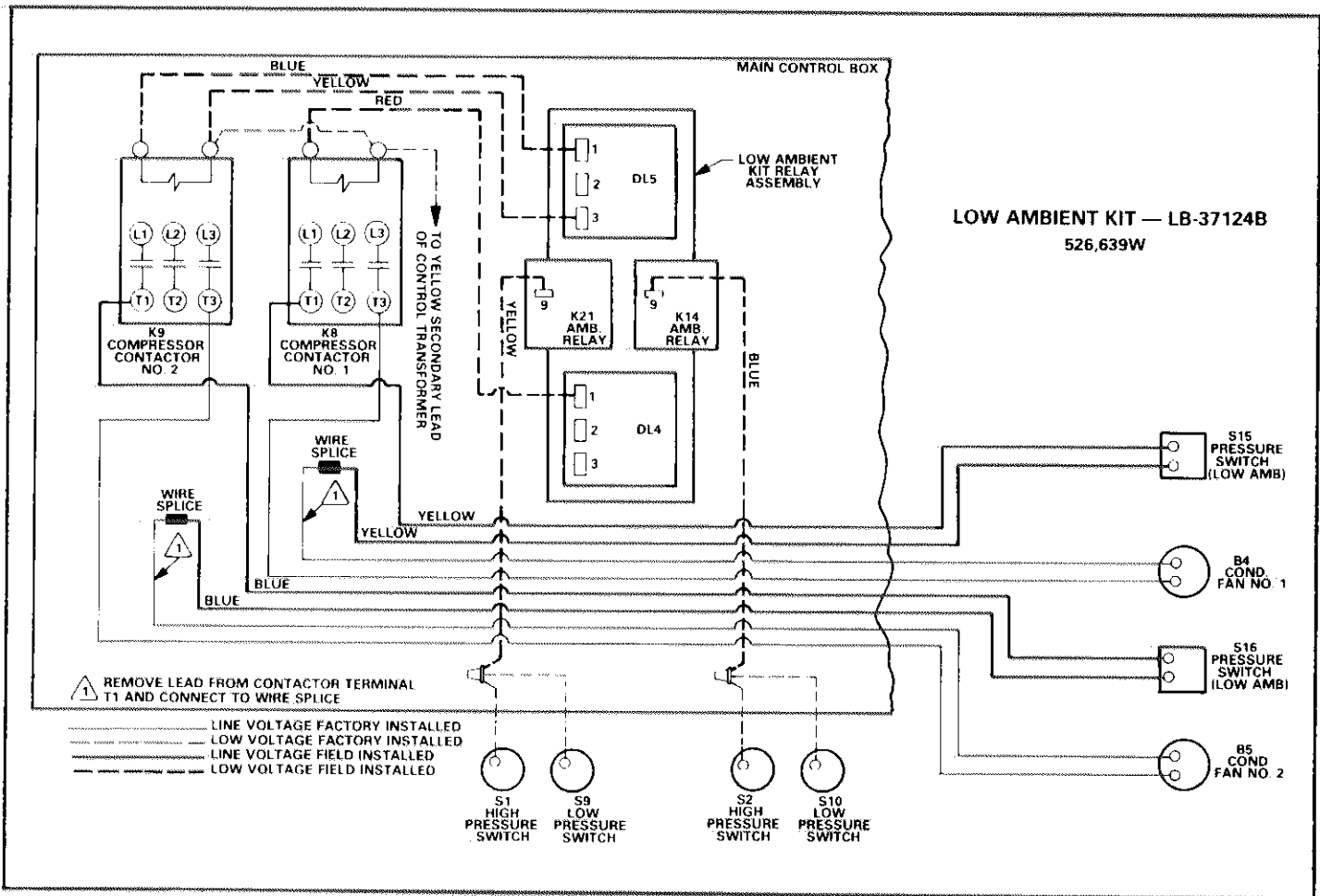

FIGURE 26

B - Fresh Air Dampers

In lieu of a power saver, the OAD11 outdoor air damper may be installed for minimum fresh air intake. This option is available with either manual or automatic damper control (damper motor). The damper motor has a remote minimum position control. This control rotates counter-clockwise to open and clockwise to close outdoor air dampers. Table 8 lists the percentage of fresh air per damper blade dimension opening.

C - Low Ambient Kit (LB-37124B)

This kit allows cooling operation at low outdoor ambients. It provides a momentary low pressure switch by-pass during compressor start-up and also cycles condenser fan to maintain adequate head pressure. Figure 26 shows field hook-up.

Low ambient relay (K14 or K21) is energized with the compressor contactor on a cooling demand to close the relay contacts. Low ambient delay (DL4 or DL5) provides a 30 second timed on circuit to by-pass the compressor low pressure switch. The compressor will stop after 30 seconds if the low pressure switch does not close.

Pressure switches S15 and S16 are wired in series with the condenser fan. Pressure switch set points are:

- open @ 140 psig
- reset @ 180 psig

When discharge pressure drops below S15 or S16 setpoint the fan cycles off until the discharge pressure rises to automatically reset low ambient pressure switch.

D - Night Setback

A Night Setback Kit (LB-38134CB) is available. The 24 hour skip-a-day clock programs a daily schedule. Any day or days

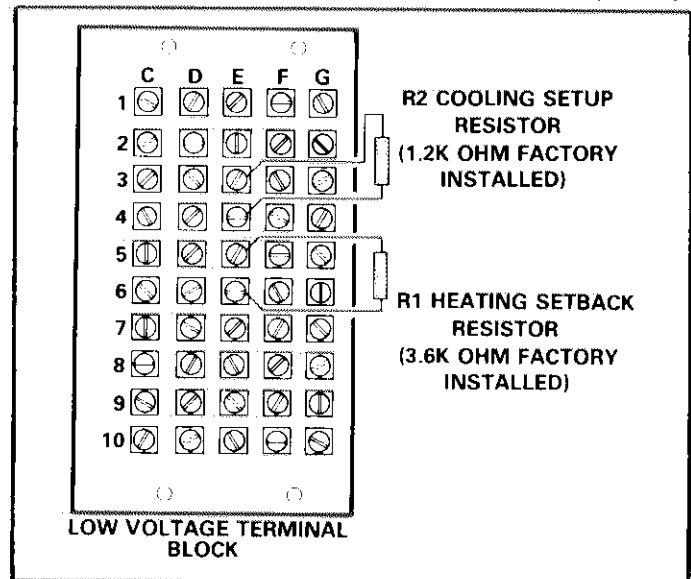
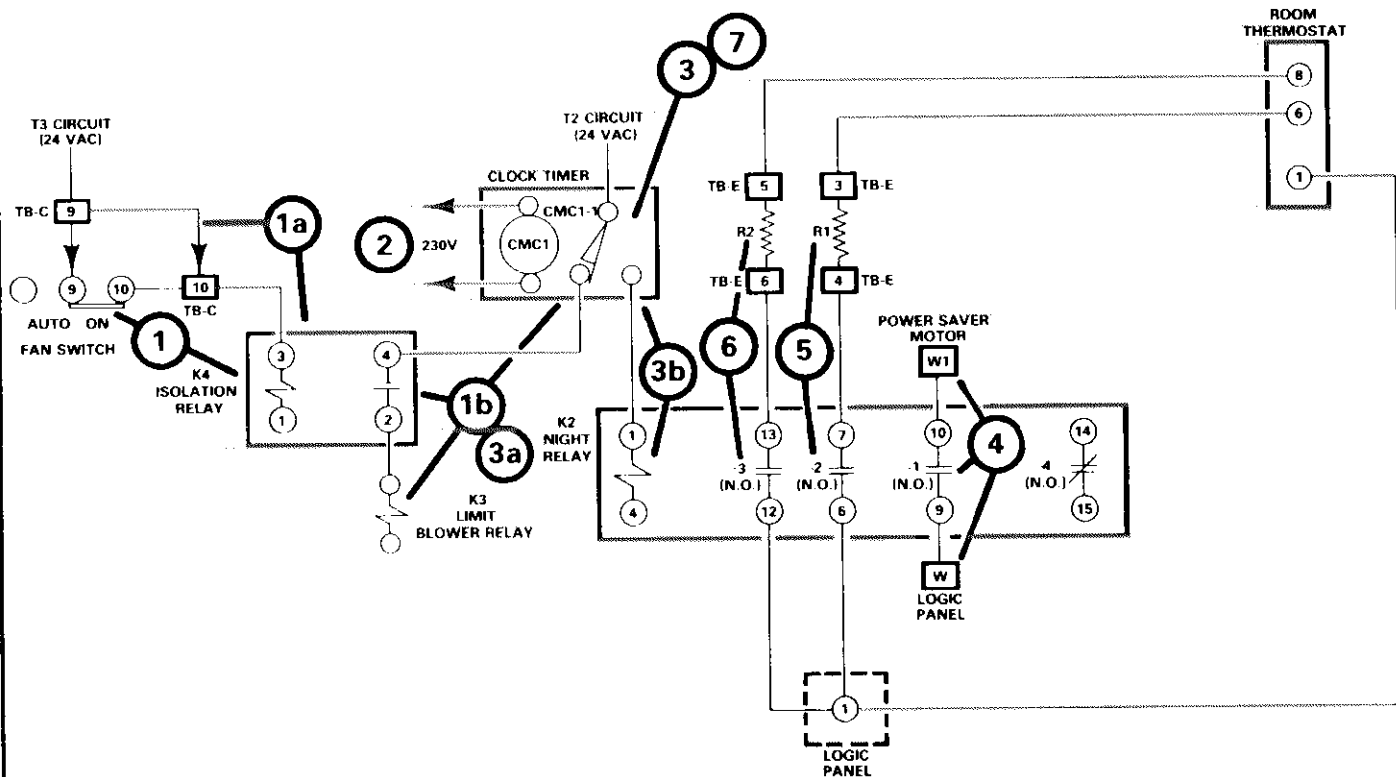

FIGURE 27

GCS11 NIGHT SETBACK OPERATION WITHOUT SSP11 SWITCHING STATUS PANEL



- 1 - On applications using optional switching subbase, the fan switch energizes K4 Isolation Relay when placed in the "on" position.
- 1a - On applications less switching subbase, K4 is energized constantly.
- 1b - N.O. K4-1 contacts close. During day operation T2 potential feeds through N.C. CMC1 contacts and K4-1 contacts to energize K3 Limit Blower Relay. K3 in turn energizes the blower motor.
- 2 - Clock timer motor is powered by 230 VAC.
- 3 - At a preset time, clock timer contacts shift position to initiate the unoccupied mode.
- 3a - N.C. CMC1-1 contacts break to de-energize the K3 circuit. The blower motor will operate intermittently on a heating or cooling demand.
- 3b - N.O. CMC1-1 contacts make to energize K2 Night Relay.
- 4 - N.O. K2 1 contacts close to jumper "W" on logic panel directly to "W1" on power saver motor. This drives motor closed.
- 5 - N.O. K2 2 contacts close to bring "R1" heating resistor into heating thermostat circuit. The amount of setback is dependent upon resistor size.
- 6 - N.O. K2-3 contacts close to bring "R2" cooling resistor into cooling thermostat circuit. The amount of setup is determined by resistor size.
- 7 - At the end of unoccupied mode, clock timer contacts open to return unit to normal operation.

FIGURE 28

can be omitted. Wiring consists of jack plug connections in blower compartment. Simply remove the existing male connection from jack plug and insert time clock connection.

The degree of heating setback or cooling setup is determined by separate resistors located at the low voltage terminal block. See Figure 27. The resistors can be substituted according to Table 9 to obtain the desired setting. Substitute resistors must be within 10% tolerance.

When an application includes night setback and switching status panel options, the "After Hour Timer" function must be field wired into the night setback circuit. Refer to Figure 4 on page 11 for field hook-up.

Figures 28 and 29 explain night setback operation.

TABLE 9

°F	Night Setback (R1)	Cool Setup (R2)
5	7.5K	20K
7	----	18K
9	----	16K
10	3.6K*	15K
13	----	13K
15	2K	12K
Cool Lockout	----	1.2K**

*This resistor is factory installed for heating. There is a 7.5K resistor taped to side of low voltage junction box.
 **This resistor is factory installed for cooling. Establishing a cooling setup value with a resistor of less than 1.2K ohm resistance will limit the maximum heat setback value to 12°F.

GCS11 NIGHT SETBACK OPERATION USING SSP11 SWITCHING STATUS PANEL

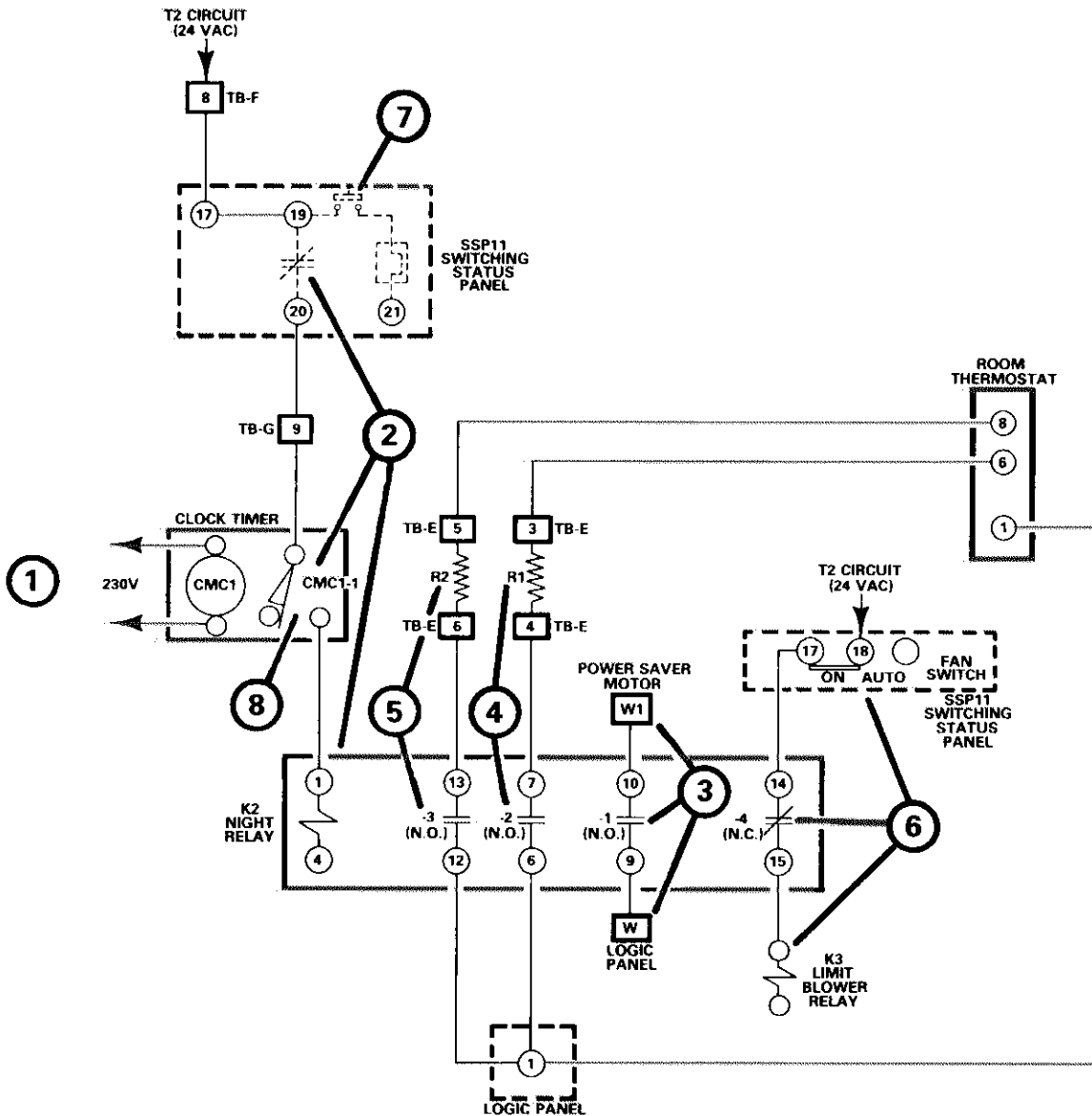

- 1 - Clock timer is powered by 230 VAC.
- 2 - At a preset time, N.O. CMC1-1 contacts close to energize K2 through the after hours function at SSP11 status panel. This initiates the unoccupied mode.
- 3 - N.O. K2-1 contacts close to jumper "W" on logic panel directly to "W1" on power saver motor. This drives motor closed.
- 4 - N.O. K2-2 contacts close to bring "R1" heating resistor into heating thermostat circuit. The amount of setback is dependent upon resistor size.
- 5 - N.O. K2-3 contacts close to bring "R2" cooling resistor into cooling thermostat circuit. The amount of setup is determined by resistor size.
- 6 - N.C. K2-4 contacts open to de-energize K3 Limit Blower Relay. The blower motor will operate intermittently on a heating or cooling demand.
- 7 - If the "After Hours Timer" on SSP11 is pressed, the circuit opens for the designated period. This de-energizes K2 to temporarily return unit into normal operation. At the end of designated period, the SSP11 timer again makes to return system into the unoccupied mode.
- 8 - At the end of unoccupied mode, clock timer contacts open to return unit to normal operation.

FIGURE 29

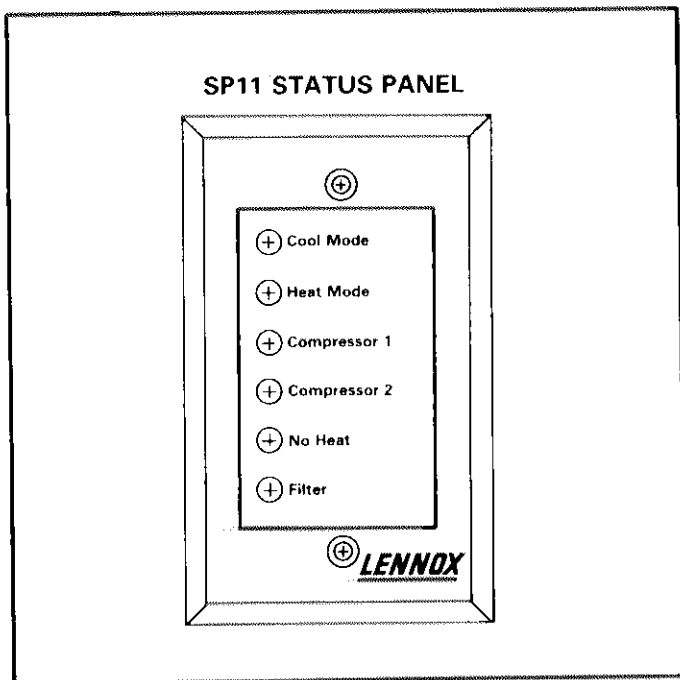

FIGURE 30

E - Status Panel Options

The status panel allows remote monitoring of system operation. Two types of panels are available. The SP11 provides system readout only. The SSP11 switching status panel combines the switching subbase and status panel functions together. In addition the SSP11 has a night setback override. Figures 30 and 31 show both panels.

- 1 - The "Cool Mode" LED is green when lit. It indicates Power Saver operation when unit is so equipped. Otherwise the LED will indicate DX cooling operation.
- 2 - The "Heat Mode" LED lights green during heating operation. The system switch on the SSP11 panel includes an emergency heat position. This function is not applicable to the GCS11; however, the "Heat Mode" light will change to red if the switch is placed at emergency heat. To avoid confusion, cut out the yellow wire at the SSP11. This prevents light from changing to red.
- 3 - The "Compressor 1" and "Compressor 2" LED's are green when the respective compressors are running. Either light will turn red if a compressor safety switch opens during a compressor demand.
- 4 - The "No Heat" LED lights red on a loss of heat. A circuit consisting of a no heat relay (K25) and a no heat delay (DL7) within the GCS11 detects a no heat situation.
- 5 - The "Filter" LED will light red when the field installed filter pressure switch (S14) contacts close indicating a dirty filter.
- 6 - The "System" switch on the SSP11 has five positions to indicate the following modes:
 - OFF - System off.
 - HEAT - Heating only.
 - AUTO - System automatically provides heating or cooling on demand.
 - COOL - Cooling only.
 - EMERGENCY HEAT - Not applicable

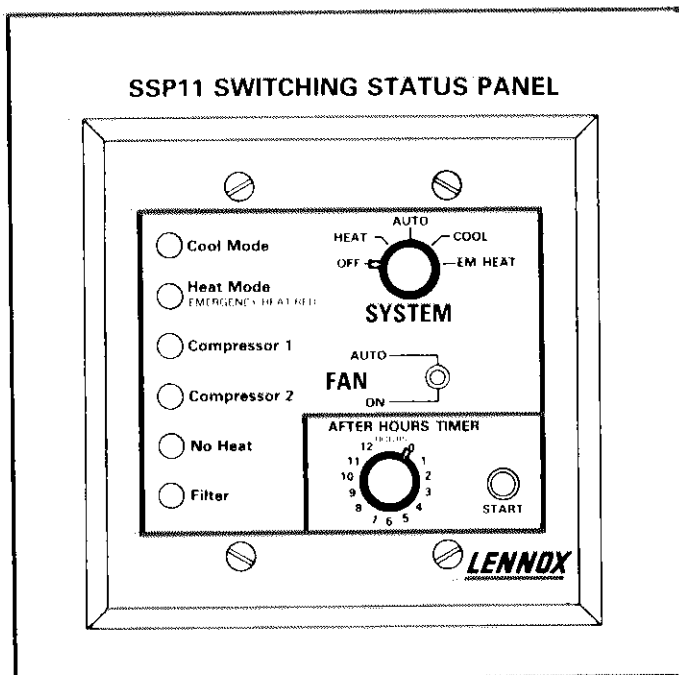

FIGURE 31

- 7 - The "Fan" switch on the SSP11 has two positions to indicate the following modes:
 - AUTO - Blower cycles with demand.
 - ON - Blower runs continuously.
- 8 - The "After Hours" timer on the SSP11 provides an override of night setback from 0 to 12 hours. A momentary push button switch initiates the time period.

IX - FIRESTATS

Some local codes may require the installation of supply air and return air firestats to automatically shut down the equipment at excessive temperatures. These field provided firestats must be mounted and wired per local codes. Manual reset type controls must be accessible. Figure 32 illustrates two suggested methods of wiring the firestats into the control circuit. When a firestat opens, the control circuit is de-energized and the unit shuts down.

X - MAINTENANCE

A - Lubrication

Always relubricate motors according to manufacturer's lubrication instructions on each motor. If no instructions are provided, use the following as a guide:

- 1 - Indoor Blower Motor Bearings - Bearings are prelubricated. For extended bearing life, relubricate at least once every two years with a lithium base grease, such as Westinghouse 53701RW, Chevron BRB2 (Standard Oil) or Andok 260 (Exxon). To relubricate, replace top plugs with standard grease fittings. Remove lower outlet plugs and add grease with handgun until new grease appears at bottom outlets. Run motor for a short time before replacing bottom plugs.
- 2 - Condenser Fan Motors - Some motors employ ball bearings which need no further lubrication. Check motor for particular lubrication requirements.

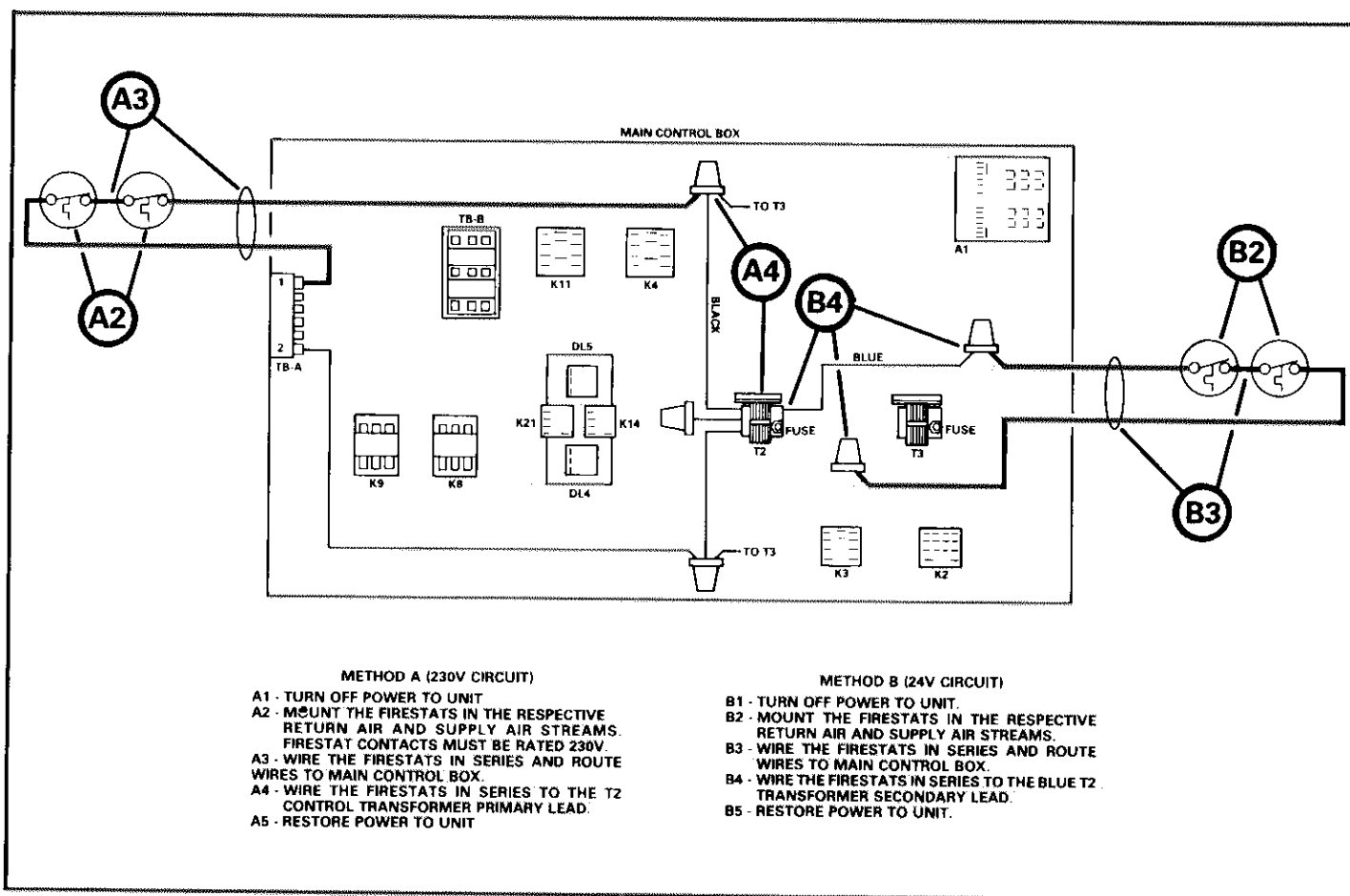

FIGURE 32

B - Filters

Inspect filters at least twice annually. Units equipped with optional status panel will indicate when filters are dirty or plugged resulting in restricted air flow. Replace the 16 in. x 20 in. x 1 in. frame type filters with equivalent filters available from your Lennox dealer.

C - Outdoor Coil

Annually rinse the outdoor fin coil with water to remove dirt or other accumulation.

D - Compressor Oil Charge

GCS11-953 with Bristol compressors uses 65 oz. of the type Suniso 3GS per compressor.

GCS11-953 with Copeland compressors uses 60 oz. of heat pump grade mineral oil of 190 to 210 viscosity per compressor.

GCS11-1353 with Bristol compressors used 65 oz. of the type Suniso 3GS per compressor.

GCS11-1353 with Copeland compressors uses 72 oz. of heat pump grade mineral oil of 190 to 210 viscosity per compressor.

XI - GENERAL SCHEMATIC INFORMATION

- 1 - The unit schematic wiring diagram format incorporates a horizontal power line which separates the line voltage circuit (motors-compressors-electric elements) from the controlling circuit. The motors, compressors and electric elements are located below the power line with the controlling circuit directly above the line.
- 2 - The graphic symbols for components and code lettering conforms to the "IEEE Standard and American National Standard" of graphic symbols for electrical diagrams. All symbols and code lettering used are approved by the International Electrotechnical Commission (IEC). Refer to Figure 33 for code and symbol identification.
- 3 - Terminal numbers on jack plugs are located by a ridge on the corner of the plug called the "Key." Refer to Figure 34 for proper numbering sequence. Jack plugs are shown in the schematic circuit by both jack plug number and terminal number. For example JP2-5 indicates jack plug number 2 and terminal number 5.
- 4 - Optional circuits are shown with arrow connections. For example the power transformer (T1) shown in the unit schematic is only used in "G" and "J" voltages.
- 5 - Solid lines around a control indicate a complete control. Dashed lines around a control indicate only a part of a control. For example the primary control (A2) is shown with a solid line in the schematic, while the logic panel (A1) is dashed.

6 - Pages 32 and 33 show a complete GCS11 unit schematic for an application including SSP11 switching status panel and power saver. Pages 34 and 35 show another GCS11 unit schematic for switching subbase, SP11 status panel, power saver and electric heat.

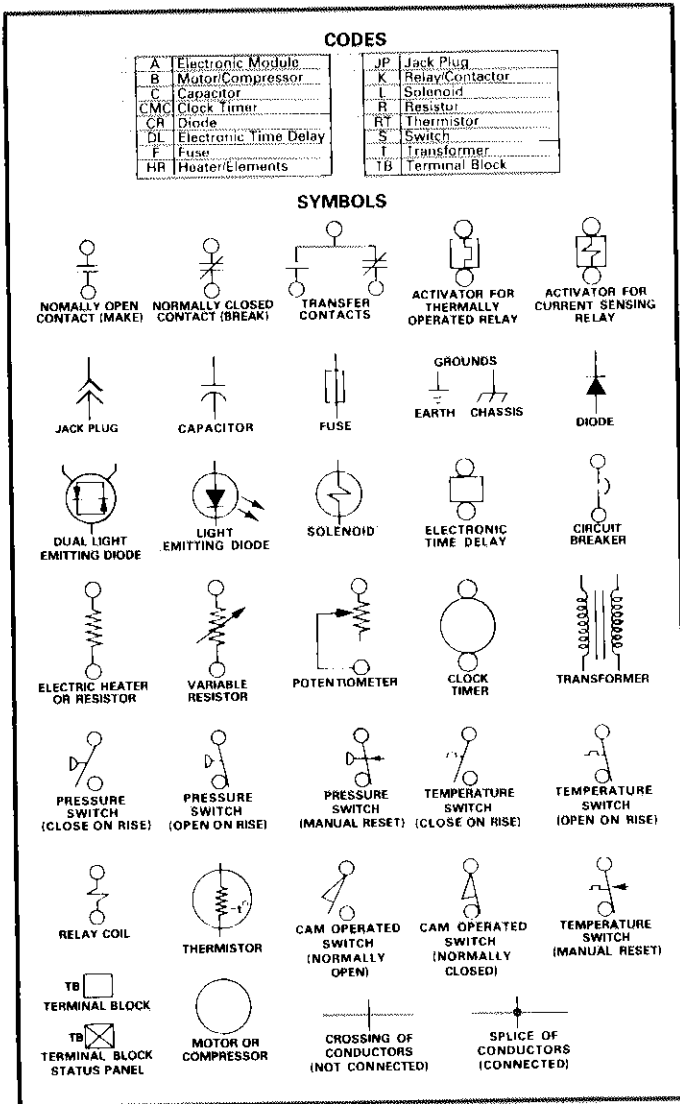

FIGURE 33

XII - SCHEMATIC WIRING DIAGRAM OPERATING SEQUENCE

Figures 35 and 36 illustrate the cooling and heating operating sequence for a typical GCS11. Each step is labeled in the corresponding diagram. The K26 Heat Readout Relay, which was added to later production units, is not shown.

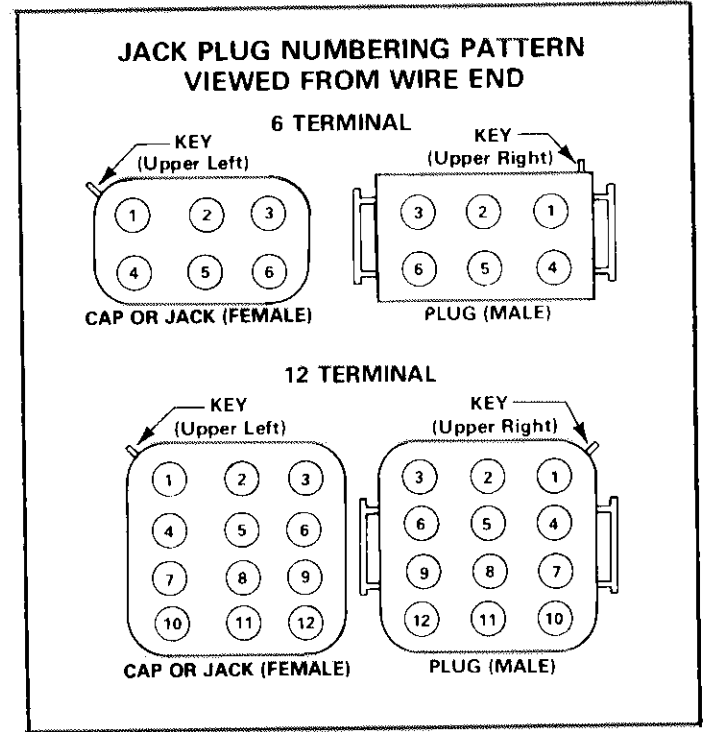
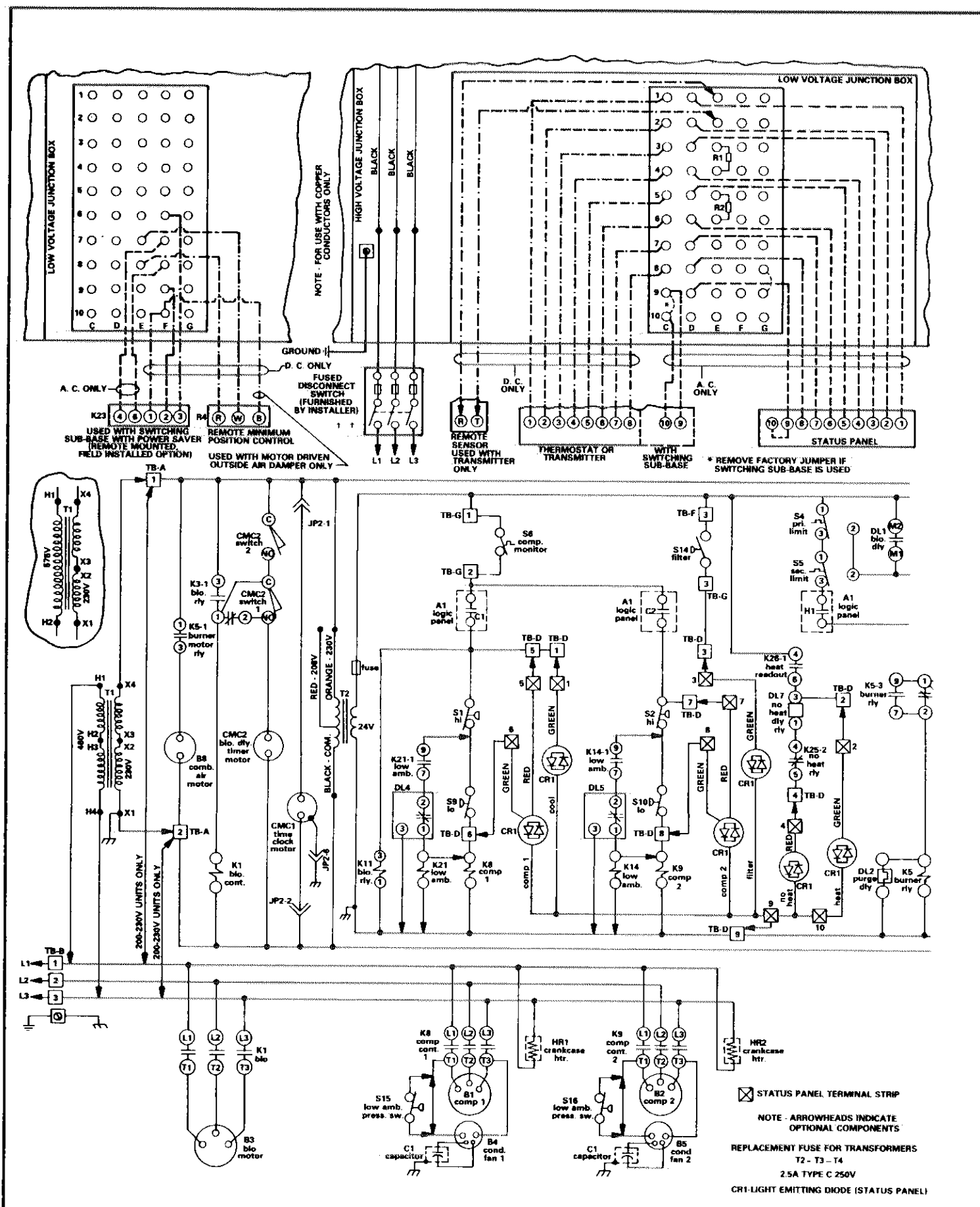
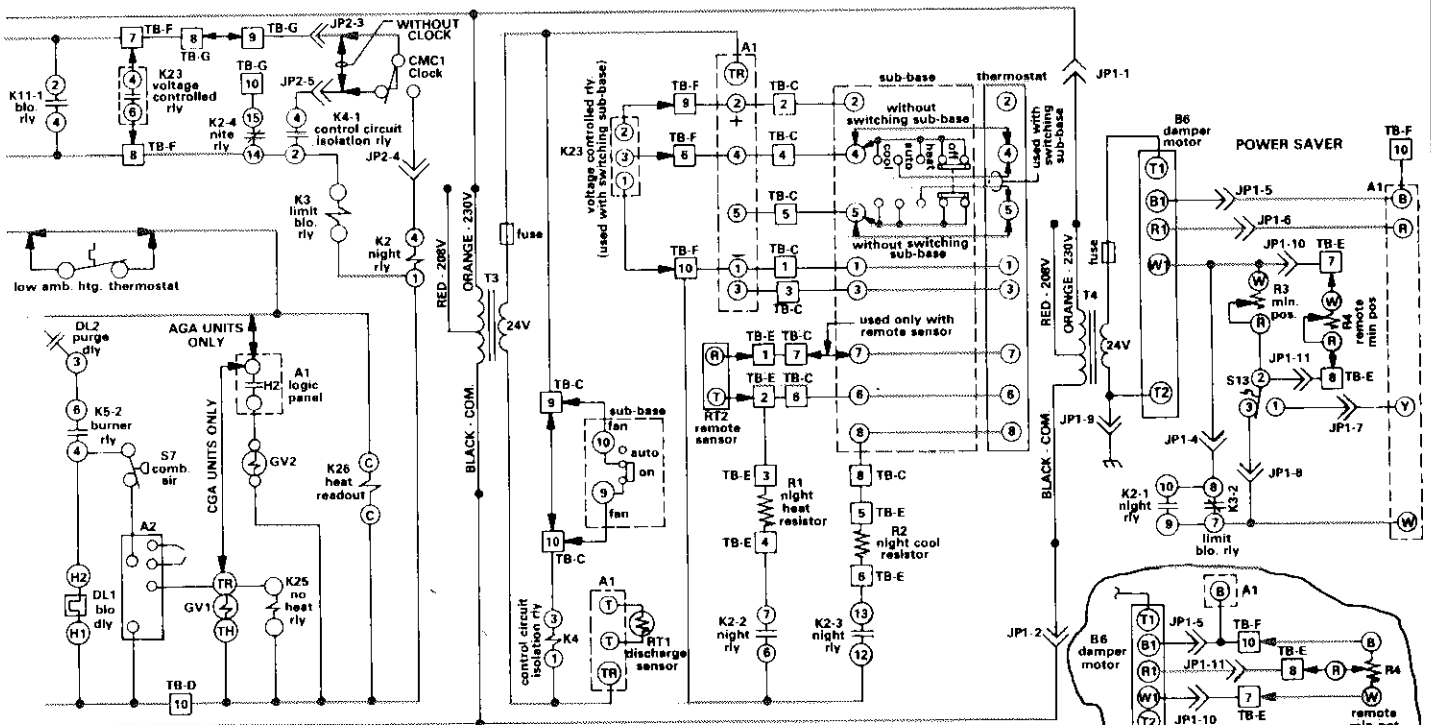
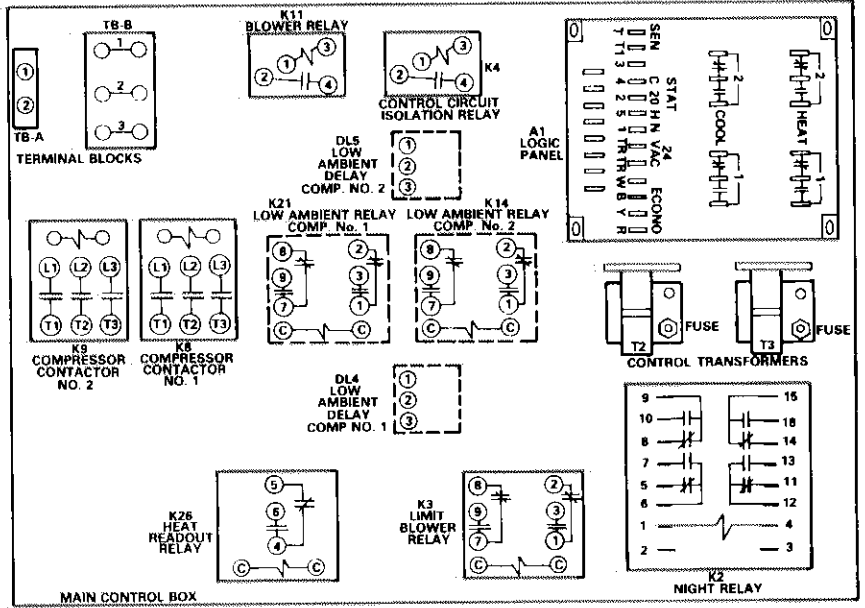
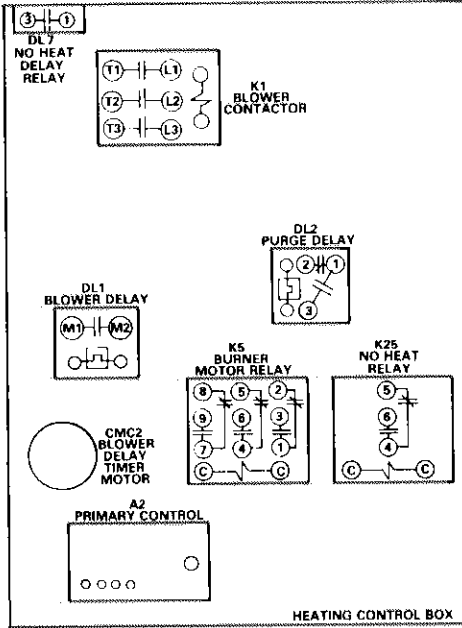

FIGURE 34



GCS11 WITH SWITCHING SUBBASE, SP11 STATUS PANEL, POWER SAVER AND ECH11 ELECTRIC HEAT



11 FOR MAXIMUM FUSE SIZE AND MINIMUM CIRCUIT AMPACITY RATING REFER TO UNIT NAMEPLATE

NOTE — IF ANY WIRE IN THIS APPLIANCE IS REPLACED, IT MUST BE REPLACED WITH WIRE OF LIKE SIZE, RATING AND INSULATION THICKNESS IF RATING AND INSULATION IS UNKNOWN, USE SAME SIZE THERMOPLASTIC 105°C WIRE WITH 4.64" INSULATION THICKNESS. THE HIGH VOLTAGE IGNITION WIRE TO BURNER MUST BE REPLACED WITH 18 GA. 5mm INSULATION SILICONE RUBBER 250°C WIRE. THE FLAME SENSOR WIRE MUST BE REPLACED WITH 18 GA. 2.64" INSULATION 200°C SILICONE WIRE.

CMC2 TIMER OPERATION

- BEGINNING A HEAT OR COOL CYCLE, (THRU SWITCH 1) TIMER RUNS FROM 360° to 24°.
- AT END OF HEAT OR COOL CYCLE, (THRU SWITCH 2) TIMER STARTS AT 24°, KEEPING THE BLOWER ON FOR APPROX. 3 MIN. & STOPS AT 380°.



- LOW VOLTAGE FACTORY INSTALLED
- LINE VOLTAGE FACTORY INSTALLED
- LOW VOLTAGE A.C. FIELD INSTALLED - NEC OR CEC CLASS 2
- LOW VOLTAGE D.C. FIELD INSTALLED - NEC OR CEC CLASS 2
- LINE VOLTAGE FIELD INSTALLED - NEC OR CEC CLASS 1

LENNOX Industries Inc.	WIRING DIAGRAM	10/80
COMBINATION UNITS - ROOFTOP		
GCS11-953-250-1W,Q,G,J GCS11-1353-350-1W,Q,G,J (WITH SP11 STATUS PANEL)		
Supersedes Form No.	New Form No. 526,771W	

Lrbo U.S.A.

**TYPICAL GCS11 COOLING SEQUENCE OF OPERATION
(SHOWN WITH SWITCHING SUBBASE LESS NIGHT SETBACK. (SEE FIGURE 35.)**

1 - On "G" and "J" voltage units, the power transformer (T1) provides the 230V control circuit. On "W" and "Q" units, the 208Y/230V control circuit uses line voltage. T1 is energized continuously.

CONTINUOUS BLOWER

2 - On applications less switching subbase, isolation relay (K4) is energized continuously by thermostat transformer (T3). On applications using switching subbase, the fan switch energizes K4 when placed in the "on" position.

3 - N.O. K4-1 contacts close to energize limit blower relay (K3).

4 - N.O. K3-1 contacts close to energize K1, which then powers blower motor. In addition, on power saver applications N.C. K3-2 contacts open to permit power saver operation.

Note - Figure 37 explains blower operation for applications using the SSP11 switching status panel. This machine is designed for continuous blower operation unless the optional fan switch (used with switching subbase or switching status panel) is set to "auto" or the optional night setback function is activated.

INTERMITTENT BLOWER

5 - The room control and discharge sensor generate a cooling ramp signal based on the cooling demand.

6 - On power saver applications, K23 voltage control relay makes on a cooling ramp signal of 4VDC. This energizes K3 to permit power saver operation and to bring on the blower motor per step 4.

7 - When N.O. K3-1 contacts close, they also complete a circuit to blower delay timer motor (CMC2) through

switch 1. CMC2 rotates 24° before switch 1 breaks to stop motor. Switch 2 makes at 13°. CMC2 is in position for extended blower operation at the end of the cooling cycle.

8 - The power saver dampers modulate in response to the cooling ramp signal, discharge low limit feature and enthalpy control setting. The range is 1.5 to 4VDC. The dampers are in minimum position at 1.5 volts and are open at 4VDC.

9 - The logic panel switches its contacts also in response to the cooling ramp signal. At approximately 5VDC, "C1" closes at logic panel.

10 - As "C1" closes, it energizes K8 No. 1 Compressor Contactor through:

S6 - Cooling Lockout Thermostat (Comp. monitor)

S1 - High Pressure Switch (manual reset)

S9 - Low Pressure Switch (auto reset)

11 - N.O. K8-1 contacts close to energize both the No. 1 compressor and condenser fan.

12 - If a low ambient kit is used, K21 is energized with K8. It latches itself in to bypass S9 and allow a compressor start-up. After DL4 times out (30 seconds), this circuit opens and S9 is again in control circuit.

13 - "C1" also energizes blower relay (K11). On applications less power saver N.O. K11-1, contacts close to then energize K3. This brings on the blower motor per step 4 and runs CMC2 per step 7.

14 - "C2" closes at a cooling ramp signal of approximately 6.75 VDC.

15 - This energizes K9 No. 2 compressor contactor

through:

S6 - Cooling Lockout Thermostat (Comp. monitor)

S2 - High Pressure Switch (manual reset)

S10 - Low Pressure Switch (auto reset)

16 - N.O. K9-1 contacts close to energize both the no. 2 compressor and condenser fan.

17 - If there is a low ambient kit, K14 is energized with K9. It latches itself in to bypass S10 and allow a compressor start-up. After DL5 times out (30 seconds), this circuit opens and S10 is again in control circuit.

18 - On low ambient applications, S15 and S16 shut off the respective condenser fan when head pressure drops below 250 psig.

19 - The logic panel opens the switches in reverse order according to cooling ramp signal:

C2 opens at approximately 5.75 VDC

C1 opens at approximately 4VDC

K23 opens between 2.5VDC - 3VDC

20 - When "C1" opens on applications less power saver or "K23 opens on applications with power saver, K3 is de-energized. When N.C. K3-1 contacts make, circuits are completed to CMC2 and K1 through switch 2. The blower motor continues to operate. CMC2 revolves from 24° to 360° before switch 2 breaks to stop timer motor. It takes approximately 3 minutes to travel the distance. When switch 2 breaks, K1 is de-energized and the blower motor stops. Switch 1 makes at 349° in preparation for next cycle.

Note - As K3 is de-energized, N.C. K3-2 will also make to drive outside dampers closed.

GCS11 COOLING SEQUENCE OF OPERATION

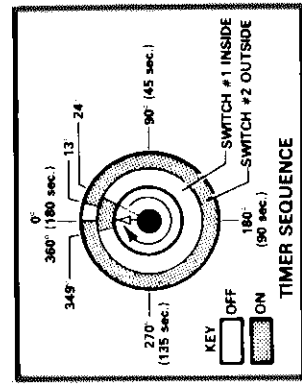
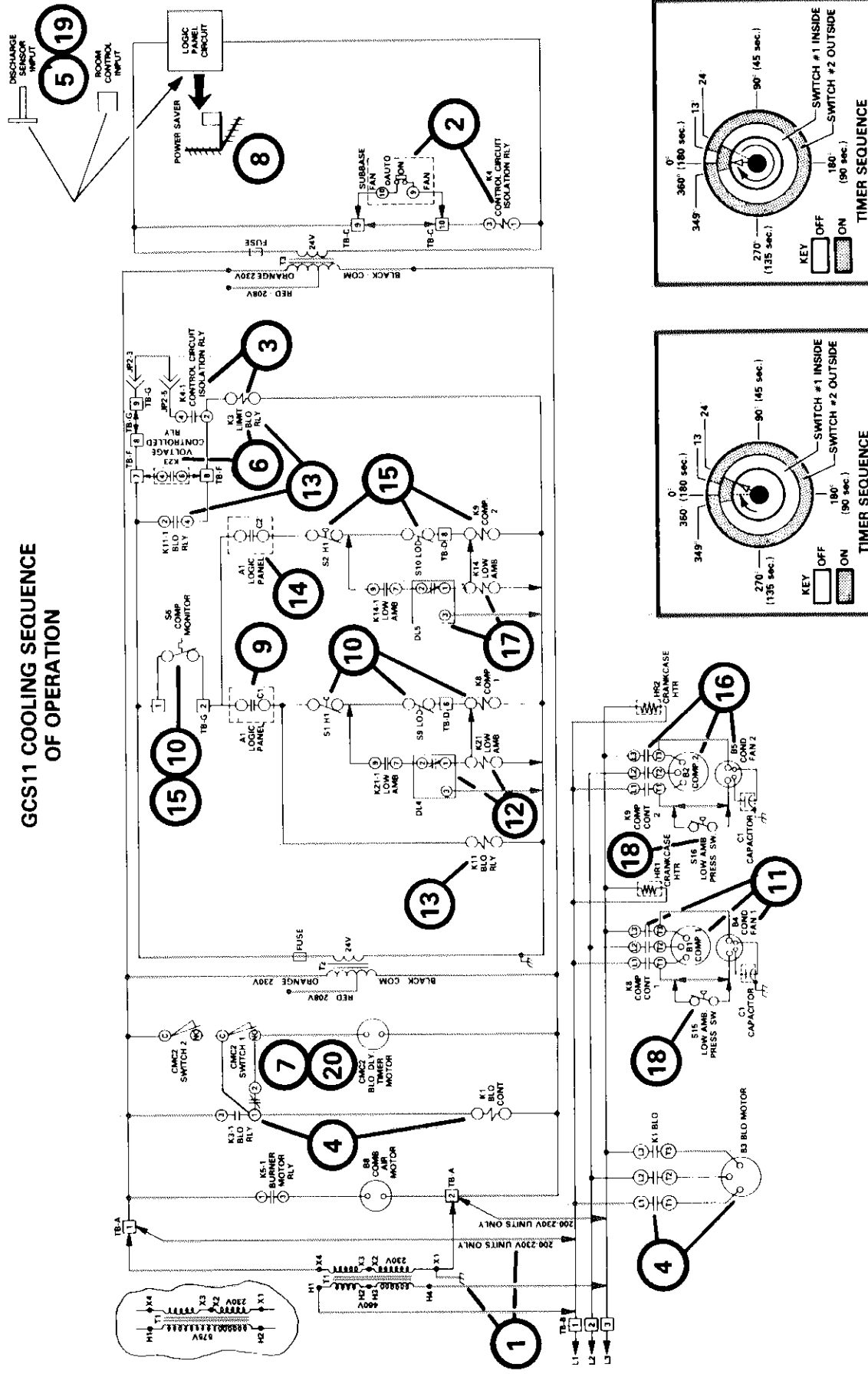

STEP 20 DETAIL

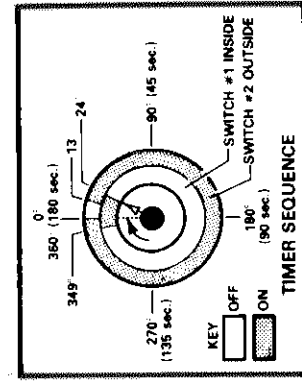

STEP 7 DETAIL

FIGURE 35
Page 37

**TYPICAL GCS11 HEATING SEQUENCE OF OPERATION
(SHOWN WITH SWITCHING SUBBASE LESS NIGHT SETBACK. (SEE FIGURE 36.)**

1 - On "G" and "J" voltage units, the power transformer (T1) provides the 230V control circuit. On "W" and "Q" units, the 208V/230V control circuit uses line voltage. T1 is energized continuously.

CONTINUOUS BLOWER

2 - On applications less switching subbase, isolation relay (K4) is energized continuously by thermostat transformer (T3). On applications using switching subbase, the fan switch energizes K4 when placed in the "on" position.

3 - N.O. K4-1 contacts close to energize limit blower relay (K3).

4 - N.O. K3-1 contacts close to energize K1. K1 then powers blower motor. In addition, N.C. K3-2 contacts open to permit the outside dampers to go to minimum position on power saver applications.

Note - Figure 37 explains blower operation for applications using the SSP11 switching status panel. This machine is designed for continuous blower operation unless the optional fan switch (used with switching subbase or switching status panel) is set to "auto" or the optional night setback function is activated.

INTERMITTENT BLOWER

5 - The room control and discharge sensor generate a heating ramp signal based on the heating demand.

6 - A heating ramp signal of approximately 5VDC closes "H1" at the logic panel.

7 - This energizes burner relay (K5) and purge delay relay (DL2) through S4, S5, low ambient heating thermostat, and N.C. DL2-1 contacts.

*NOTE - THE LOW AMBIENT HEATING THERMOSTAT IS ONLY USED ON C.G.A. UNITS CERTIFIED FOR OPERATION IN AMBIENT TEMPERATURES TO - 60°F.

8 - N.O. K5-1 contacts close to activate the combustion air blower motor (B8).

9 - N.O. K5-2 contacts close to permit an ignition attempt.

10 - N.O. K5-3 contacts close to latch in the K5 relay and to keep DL2 energized after N.C. DL2-1 contacts break.

11 - The DL2 "on time" (25 to 55 seconds) permits a purge period to vent out combustion chamber before an ignition attempt is made. N.O. DL2-1 contacts make to energize blower delay relay (DL1) through K5-2 contacts which were made in step 9.

12 - N.O. DL1 contacts make in 5 to 30 seconds to energize K3 and initiate blower operation. See step 4.

13 - When N.O. K3-1 contacts close, they also complete a circuit to blower delay timer motor (CMC2) through switch 1. CMC2 rotates 24° before switch 1 breaks to stop motor. Switch 2 makes at 13°. CMC2 is in position for extended blower operation at the end of the heating cycle.

14 - When N.O. DL2-1 contacts make in step 11, they also activate the primary control (A2) through K5-2 and S7. S7 closes with the presence of combustion air.

15 - The primary control energizes the first stage gas valve (GV1). The control also initiates sparking at the electrodes. With sparking and gas flow, ignition is established.

16 - If ignition is not established, A2 detects this by flame rectification and locks itself out in approximately 7 seconds. This de-energizes GV1.

17 - On two stage burners, a heating ramp signal of approximately 6.75VDC closes "H2" at logic panel. This

energizes the second stage gas valve (GV2). The additional gas is ignited by the existing flame at burner.

NOTE - On AGA units, "H2" is powered directly from "H1". On CGA units, "H2" is powered through primary control.

18 - Should unit temperatures exceed limit control setpoint, it breaks heating control circuit and simultaneously makes another circuit to K3. This assures indoor blower motor operation.

19 - Should there be a burner flame failure, A2 detects this condition. It will try once for re-ignition and then will lockout. This de-energizes gas valve(s) to stop gas flow to burner.

20 - The logic panel opens the "H" switches in reverse order according to heating ramp signal.

H2 opens at approximately 5.75VDC

H1 opens at approximately 4VDC

21 - When the "H" switches open, the heating control circuit de-energizes. DL1-1 contacts remain closed for the "off time" (15 - 45 seconds), but then open to de-energize K3.

22 - When N.C. K3-1 contacts close, circuits are completed to CMC2 and K1 through switch 2. The blower motor continues to operate. CMC2 revolves from 24° to 360° before switch 2 breaks to stop timer motor. It takes approximately 3 minutes to travel the distance. When switch 2 breaks, K1 is de-energized and the blower motor stops. Switch 1 makes at 349° in preparation for next cycle.

NOTE — As K3 is de-energized, N.C. K3-2 contacts will also make to drive outside dampers to closed position on power saver applications.

CONTINUOUS BLOWER OPERATING SEQUENCE FOR GCS11 WITH OPTIONAL SWITCHING STATUS PANEL

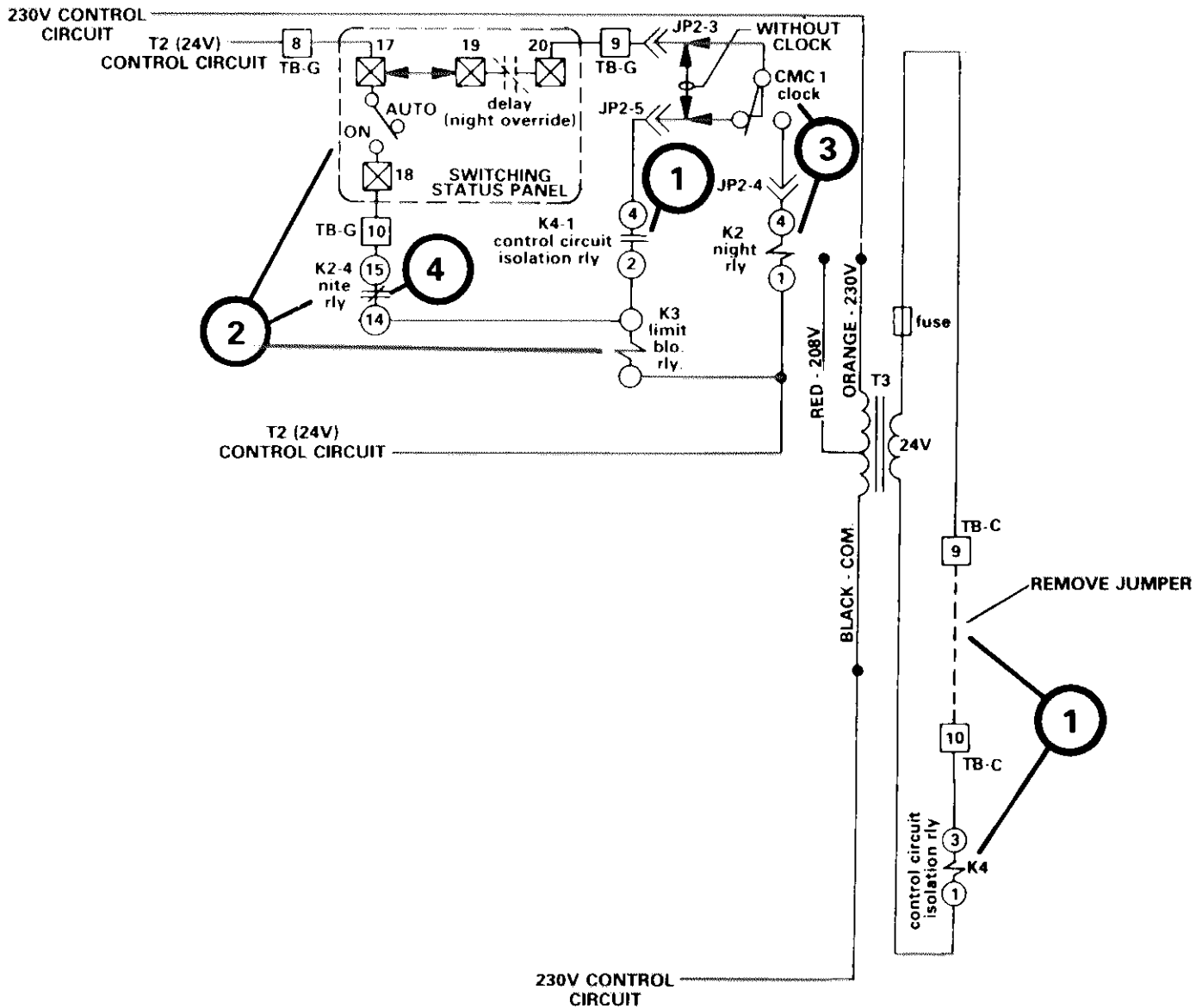

- 1 - K4 Control Circuit Isolation Relay is not used. Jumper between terminals TBC-9 and TBC-10 must be removed.
- 2 - When fan switch is placed at "on", K3 Limit Blower Relay is energized through N.C. K2-4 Night Relay. K3-1 energizes blower circuit as described in step 4 of Figures 35 and 36.
- 3 - If night setback is used, CMC1 energizes K2 Night Relay during the night setback mode.
- 4 - N.C. K2-4 opens to de-energize K3. A heating or cooling demand activates blower operation.

FIGURE 37

XIII - TROUBLESHOOTING

The GCS11 is engineered for troubleshooting convenience. Many problems can be determined at the unit make-up box before opening unit access panels. All that is needed is an ohmmeter and an AC/DC voltmeter.

Perform the checks outlined in the following flow charts. Each check shows the terminal block, meter test points and voltage.

Additional information is available for troubleshooting the Honeywell solid-state control system. Refer to the "Miscellaneous" section within this manual. Before condemning any components, be sure all terminal connections are tight in the circuit. This is particularly important on DC voltages, especially at the thermostat.

GCS11 NO HEATING OR INSUFFICIENT HEATING

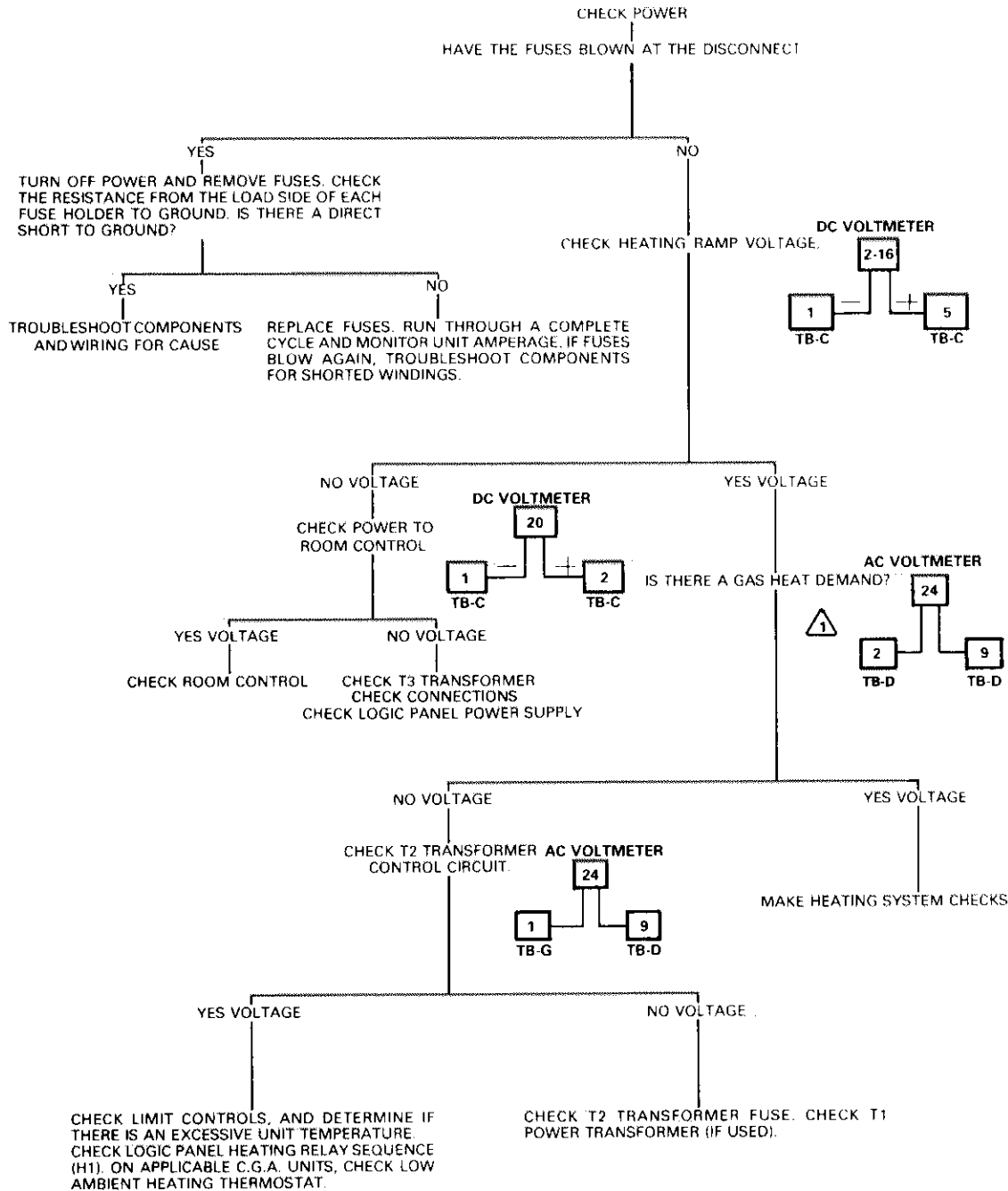

1 On later production units this terminal will be isolated by K26 Heat Readout Relay. However, terminal TBD-2 should still have potential on a heating demand.

GCS11 NO COOLING OR INSUFFICIENT COOLING

